

FAB5RCR5



| | |
|------------------|---------------|
| Product Family | Refrigerator |
| Installation | Free standing |
| Category | One Door |
| Reference width | Until 60 |
| Reference height | Until 100 |
| Cooling type | Static |
| Defrost | Automatic |
| Hinge type | Standard |
| Hinge position | Right |
| EAN code | 8017709297053 |



Aesthetics

| | | | |
|-----------|--------------|---------------|---------|
| Aesthetic | 50's Style | Handle type | Fixed |
| Colour | Cream | Handle colour | Chrome |
| Finishing | Glossy | Logo colour | Chrome |
| Design | Rounded | Side material | Steel |
| Material | Heat-moulded | Side colour | Cream |
| Handle | External | Logo | Applied |

Refrigerator compartment features



| | | | |
|----------------------------|-------|---------------------------------|-----|
| No. of adjustable shelves | 2 | Internal light in fridge | Yes |
| Type of adjustable shelves | Glass | Type of internal light (fridge) | LED |

Refrigerator Inner Door

| | | | |
|---|-----|----------------------------------|-----|
| Number of adjustable door shelves | 1 | No. of bottle shelves | 1 |
| Adjustable door shelves with wire support | Yes | Bottle shelves with wire support | Yes |

Other technical features

| | |
|-----------------------------|------------|
| Type of temperature control | Electronic |
| Refrigerant gas type | R600a |

| | |
|---------------------------|--------------|
| Type of compressor | Standard |
| Refrigerant Quantity (gr) | 19 g |
| Foam agent | Cyclopentane |

Performance / Energy Label - Reg. 2019

| | | | |
|--|----------|--|------------------|
|  Annual energy consumption | 61 kWh/a | Sum of the volumes of the chill compartment(s) and the unfrozen compartment(s) | 34 l |
| Energy efficiency class | D | Airborne acoustical noise emissions | 40 dB(A) re 1 pW |
| Airborne acoustical noise emission class | C | Climate class | SN, N, ST, T |
| Total net volume | 34 l | EEL | 79 % |

Electrical Connection

| | | | |
|------------------------------|--------------|---------------------------|-----------|
| Plug | (F;E) Schuko | Voltage (V) | 220-240 V |
| Electrical connection rating | 60 W | Frequency (Hz) | 50/60 Hz |
| Current | 0.3 A | Power supply cable length | 200 cm |

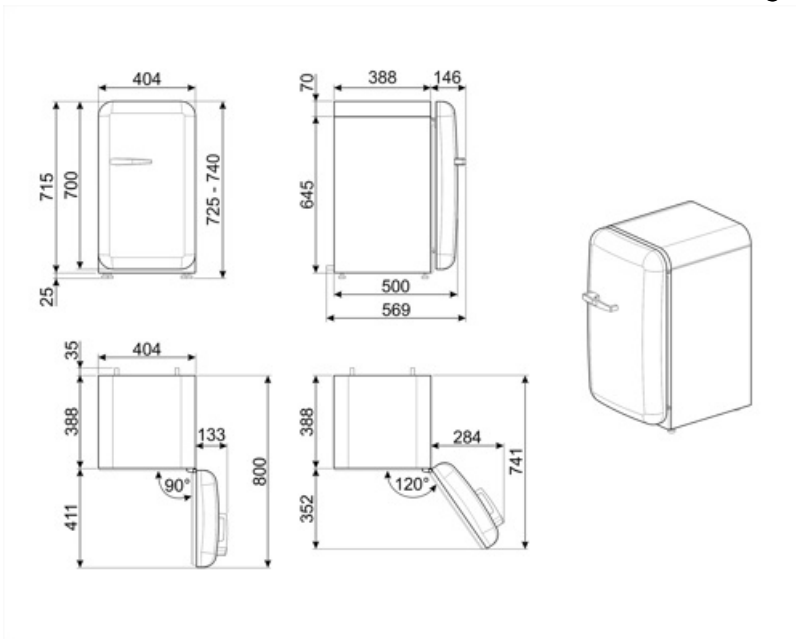





Compatible Accessories

KITCABLE90UK

Cable with IEC connector and UK plug

Symbols glossary

- | | | | |
|--|---|---|---|
|  | A+++: Appliances with this symbol can reduce energy consumption by a further 30% from the standard A energy rating. |  | The automatic defrost system works by automatically defrosting at regular intervals eliminating the need to defrost altogether. |
|  | LED interior lighting: is a more energy efficient and long lasting way of illuminating the interior of the appliance. |  | Energy efficiency class D |

Benefit (TT)

Refrigerant gas R600a

Environmentally friendly R600a refrigerant gas contributes to rapid cooling with lower energy consumption

Climate class

Climatic class SN-T makes the appliance suitable for working at room temperature between 10 °C and 43 °C (50 °F ~ 109 °F)

External handle

The external handle ensures practicality and ease of use of the refrigerator

Refrigerator Internal lighting

Interior lighting for perfect visibility of shelves in the refrigerator compartment