

FAB5RDG03



Product Family	Refrigerator
Installation	Free standing
Category	One Door
Cooling type	Static
Defrost	Automatic
Hinge type	Standard
Hinge position	Right
EAN code	8017709274481



Aesthetics

Aesthetic	50's Style	Logo colour	Gold-Swarovski
Colour	Gold	Side material	Steel
Finishing	Glossy	Side colour	Gold
Design	Rounded	Logo	Applied
Material	Heat-moulded	Door shelves profile color	Chrome
Handle	External	Drawers profile color	Chrome
Handle type	Fixed	Color of glass shelf profile	Chrome
Handle colour	Gold	Alternative colours available	Orange, Pastel blue, White, Black, Cream, Pink, Red, Silver, Pastel green, Decorated / Special

Refrigerator compartment features



No. of adjustable shelves	2	Internal light in fridge	Yes
Type of adjustable shelves	Glass	Type of internal light (fridge)	LED

Refrigerator Inner Door

Number of adjustable door shelves	1	No. of bottle shelves	1
		Bottle shelves with wire support	Yes

Adjustable door shelves Yes
with wire support

Other technical features

Type of temperature control	Electronic
Refrigerant gas type	R600a
Type of compressor	Standard
Refrigerant Quantity (gr)	19 g
Foam agent	Cyclopentane

Performance / Energy Label - Reg. 2019



Annual energy consumption	61 kWh/a	Sum of the volumes of the chill compartment(s) and the unfrozen compartment(s)	34 l
Energy efficiency class	D	Airborne acoustical noise emissions	40 dB(A) re 1pW
Airborne acoustical noise emission class	C	Climate class	SN, N, ST, T
Total net volume	34 l	EEL	79 %

Electrical Connection

Plug	(F;E) Schuko	Voltage (V)	220-240 V
Electrical connection rating	60 W	Frequency (Hz)	50/60 Hz
Current	0.22 A	Power supply cable length	100 cm

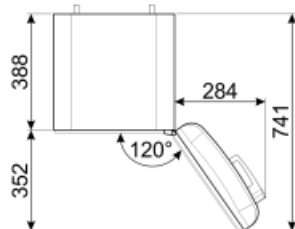
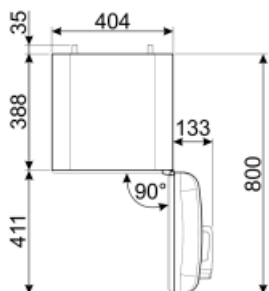
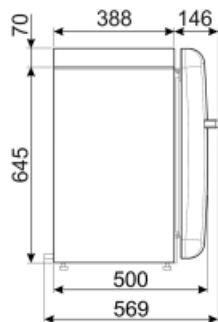
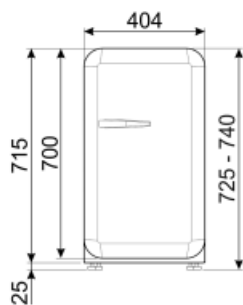

Not included accessories

KITCABLE90UK

Cable with IEC connector and UK plug

Symbols glossary (TT)



The automatic defrost system works by automatically defrosting at regular intervals eliminating the need to defrost altogether.



Energy efficiency class D



A+++: Appliances with this symbol can reduce energy consumption by a further 30% from the standard A energy rating.



LED interior lighting: is a more energy efficient and long lasting way of illuminating the interior of the appliance.