

FAB5RPG5



Product Family	Refrigerator
Installation	Free Standing
Model notes	
Category	One Door
Reference width	Until 60
Reference height	Until 100
Cooling type	Static
Defrost	Automatic
Hinge type	Standard
Hinge position	Right
EAN code	8017709299590



Aesthetics

Aesthetics	50's Style	Logo colour	Chrome
Colour	Pastel Green	Side material	Steel
Finishing	Gloss	Side colour	Pastel green
Design	Rounded	Logo	Applied
Material	Heat-moulded	Door shelves profile colour	Chrome
Handle	External	Drawers profile colour	Chrome
Handle type	Fixed	Colour of glass shelf profile	Chrome
Handle colour	Chrome		

Refrigerator compartment features



No. of adjustable shelves	2	Internal light in fridge	Yes
Type of adjustable shelves	Glass	Type of internal light (fridge)	LED

Refrigerator Inner Door

Number of adjustable door shelves	1	No. of bottle shelves	1
Adjustable door shelves with wire support	Yes	Bottle shelves with wire support	Yes

Other technical features

Type of temperature control	Electronic
Refrigerant gas type	R600a
Type of compressor	Standard
Refrigerant Quantity (gr)	19 g
Foam agent	Cyclopentane

Performance / Energy Label

			
Annual energy consumption	61 kWh/year	Sum of the volumes of the chill compartment(s) and the unfrozen compartment(s)	34 l
Energy efficiency class	D	Noise level	40 dB(A) re 1 pW
Airborne acoustical noise emission class	C	Climatic class	SN, N, ST, T
Total volume	34 l	EI	79 %

Electrical Connection

Plug	(F;E) Schuko	Voltage (V)	220-240 V
Nominal power	60 W	Frequency (Hz)	50/60 Hz
Current	0,3 A	Power supply cable length	100 cm

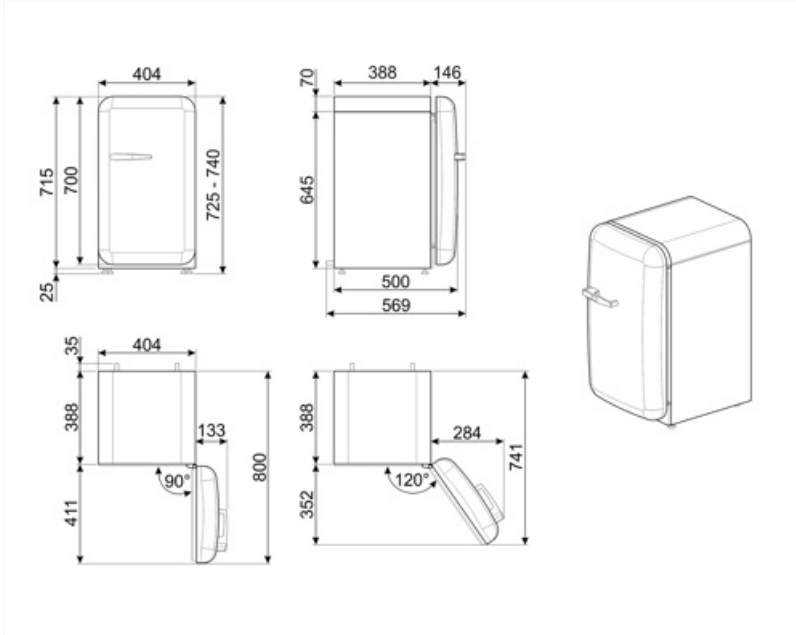

Not included accessories

KITCABLE90UK

Cable with IEC connector and UK plug

Symbols glossary



The automatic defrost system works by automatically defrosting at regular intervals eliminating the need to defrost altogether.



Energy efficiency class D



A+++: Appliances with this symbol can reduce energy consumption by a further 30% from the standard A energy rating.



LED interior lighting: is a more energy efficient and long lasting way of illuminating the interior of the appliance.