

FAB5RPG5



Product Family	Refrigerator
Installation	Free standing
Model notes	
Category	One Door
Reference width	Until 60
Reference height	Until 100
Cooling type	Static
Defrost	Automatic
Hinge type	Standard
Hinge position	Right
EAN code	8017709299590



Aesthetics

Aesthetic	50's Style	Logo colour	Chrome
Colour	Pastel green	Side material	Steel
Finishing	Glossy	Side colour	Pastel green
Design	Rounded	Logo	Applied
Material	Heat-moulded	Door shelves profile color	Chrome
Handle	External	Drawers profile color	Chrome
Handle type	Fixed	Color of glass shelf profile	Chrome
Handle colour	Chrome		

Refrigerator compartment features



No. of adjustable shelves	2	Internal light in fridge	Yes
Type of adjustable shelves	Glass	Type of internal light (fridge)	LED

Refrigerator Inner Door

Number of adjustable door shelves	1	No. of bottle shelves	1
Adjustable door shelves with wire support	Yes	Bottle shelves with wire support	Yes

Other technical features

Type of temperature control	Electronic
Refrigerant gas type	R600a
Type of compressor	Standard
Refrigerant Quantity (gr)	19 g
Foam agent	Cyclopentane

Performance / Energy Label - Reg. 2019

			
Annual energy consumption	61 kWh/a	Sum of the volumes of the chill compartment(s) and the unfrozen compartment(s)	34 l
Energy efficiency class	D	Airborne acoustical noise emissions	40 dB(A) re 1 pW
Airborne acoustical noise emission class	C	Climate class	SN, N, ST, T
Total net volume	34 l	EI	79 %

Electrical Connection

Plug	(F;E) Schuko	Voltage (V)	220-240 V
Electrical connection rating	60 W	Frequency (Hz)	50/60 Hz
Current	0.3 A	Power supply cable length	100 cm

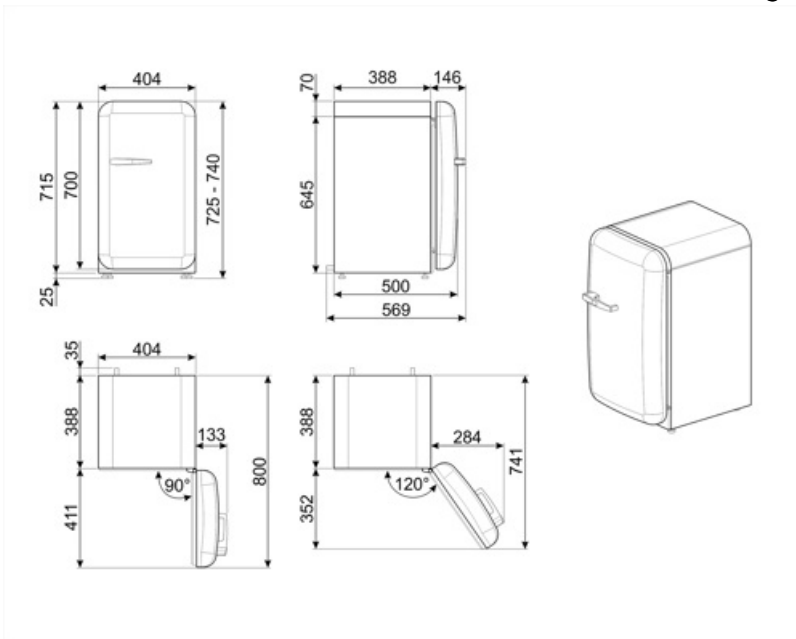

Compatible Accessories

KITCABLE90UK

Cable with IEC connector and UK plug

Alternative products



FAB5RPB5

Hinge position: Right
Pastel blue



FAB5RCR5

Hinge position: Right
Cream



FAB5RWH5

Hinge position: Right
White



FAB5RDUJ5

Hinge position: Right
Decorated / Special



FAB5RSV5

Hinge position: Right
Silver



FAB5RPK5

Hinge position: Right
Pink



FAB5RBL5

Hinge position: Right
Black



FAB5RRD5





Hinge position: Right
Red



FAB5ROR5

Hinge position: Right
Orange

Symbols glossary

- | | | | |
|--|---|---|---|
|  | A+++: Appliances with this symbol can reduce energy consumption by a further 30% from the standard A energy rating. |  | The automatic defrost system works by automatically defrosting at regular intervals eliminating the need to defrost altogether. |
|  | LED interior lighting: is a more energy efficient and long lasting way of illuminating the interior of the appliance. |  | Energy efficiency class D |

Benefit (TT)

Refrigerant gas R600a

Environmentally friendly R600a refrigerant gas contributes to rapid cooling with lower energy consumption

Climate class

Climatic class SN-T makes the appliance suitable for working at room temperature between 10 °C and 43 °C (50 °F ~ 109 °F)

External handle

The external handle ensures practicality and ease of use of the refrigerator

Refrigerator Internal lighting

Interior lighting for perfect visibility of shelves in the refrigerator compartment