

FAB5ULRD3



Product Family
Installation
Model notes

Refrigerator
Free standing
Due collegamenti presenti sul retro del prodotto: - POWER: per funzionamento del prodotto - SIGNAL: per attivare la funzione SMART Un cavo incluso (per collegamento POWER)

Category
Defrost
Hinge position
EAN code

One Door
Automatic
Left
8017709289775



Aesthetics

Aesthetic	50's Style	Side material	Steel
Colour	Red	Side colour	Red
Finishing	Glossy	Logo	Applied
Material	Heat-moulded	Alternative colours available	White, Black, Cream, Red

Refrigerator compartment features



No. of adjustable shelves	2	Internal light in fridge	Yes
Type of adjustable shelves	Wire	Type of internal light (fridge)	LED

Refrigerator Inner Door

Number of adjustable door shelves	1	No. of bottle shelves	1
Adjustable door shelves with wire support	Yes	Bottle shelves with wire support	Yes

Other technical features

Type of temperature control	Electro-mechanical
No. of compressors	1

Refrigerant gas type
Foam agent

R600a
Cyclopentane

Performance / Energy Label - Reg. 2019

Airborne acoustical
noise emissions

40 dB(A) re 1 pW

Climate class

SN, N, ST, T

Electrical Connection

Plug
Current
Voltage (V)

(A) USA e Messico
0.89 A
110 V

Frequency (Hz)
Power supply cable
length

60 Hz
70 7/8 "

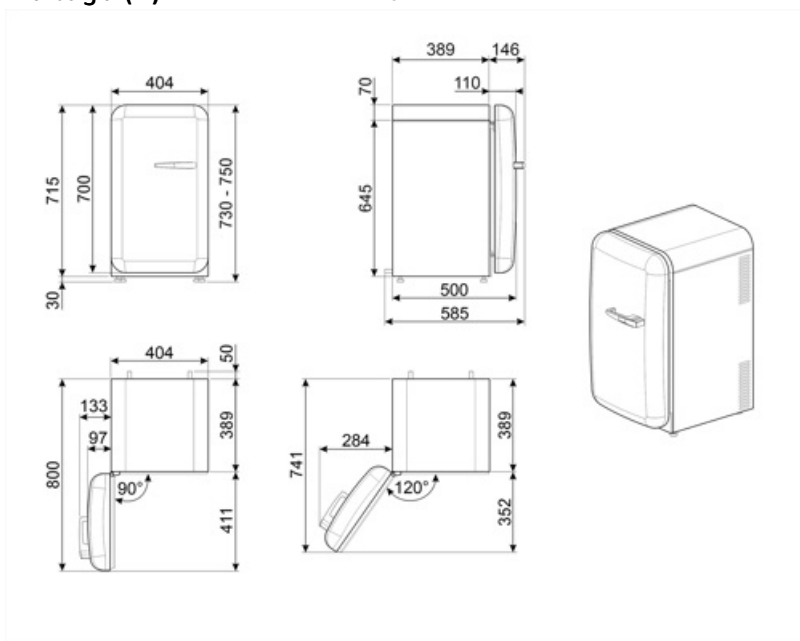

Not included accessories

KITCABLE90UK

Cable with IEC connector and UK plug

Symbols glossary (TT)



The automatic defrost system works by automatically defrosting at regular intervals eliminating the need to defrost altogether.



LED interior lighting: is a more energy efficient and long lasting way of illuminating the interior of the appliance.