

# FAB5ULYW3



Product family  
Installation  
Model notes

Refrigerator  
Free-standing  
Due collegamenti presenti sul retro del prodotto: - POWER: per funzionamento del prodotto - SIGNAL: per attivare la funzione SMART Un cavo incluso (per collegamento POWER)  
Single door  
Automatic  
Left  
8017709336523



## Aesthetic

Aesthetics	Retro-style	Side material	Steel
Color	Yellow	Side color	Yellow
Finishing	Glossy	Logo	Applied
Material	Thermo-formed		

## Refrigerator compartment features



No. of adjustable shelves	2	Refrigerator lighting	Yes
Type of adjustable shelves	Wire	Refrigerator lighting	LED
No. of lights	1		

## Refrigerator Inner Door

Number of adjustable door shelves	1	No. of bottle shelves	1
Adjustable door bins with wire support	Yes	Door bin with wire support	Yes

## Other technical features

Temperature setting type	Electro-mechanical
No. of compressors	1
Refrigerant gas type	R600a

Foam agent

Cyclopentane

## Performance / Energy Label NEW

Noise level	40 dB(A) re 1 pW	Climatic class	SN, N, ST, T
-------------	------------------	----------------	--------------

## Electrical Connection

Plug	(A) USA & Mexico	Frequency (Hz)	60 Hz
Current	0.89 A	Power cord length	70 7/8 "
Voltage (V)	110 V		

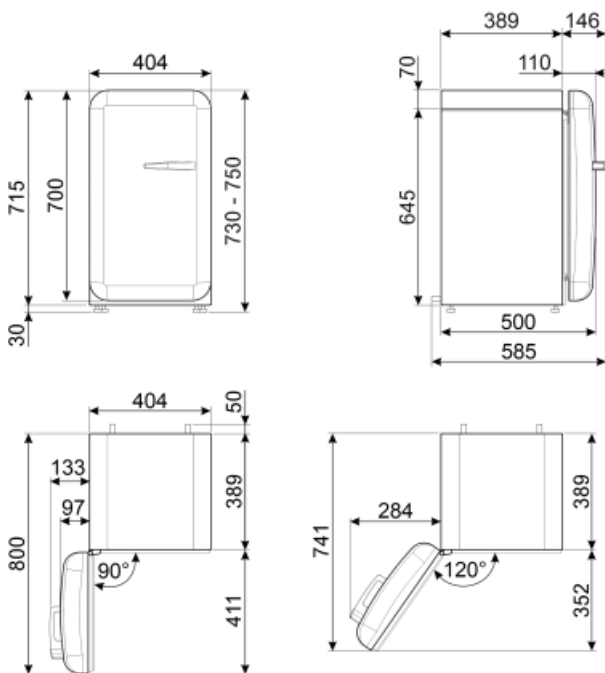

---

## Symbols glossary (TT)

---



The automatic defrost system works by automatically defrosting at regular intervals eliminating the need to defrost altogether.



LED interior lighting: is a more energy efficient and long lasting way of illuminating the interior of the appliance.