

FC18XDNE



Product Family	Refrigerator
Installation	Free Standing
Category	Bottom Mount
Reference width	Until 60 cm
No-Frost system	Yes
Cooling type	No frost
Defrost	Automatic
Hinge type	Standard
Hinge position	Right
Reversible door	Yes
EAN code	8017709303129



Aesthetics



Aesthetics	Universal	Side material	Steel
Colour	Inox Look	Side colour	Silver
Material	Steel Effect	Logo	Applied
Handle	Integrated	Display	LED
Handle type	Fixed	Display position	External (on door)
Logo colour	Chrome		

Refrigerator compartment features



No. of adjustable shelves	2	Bottle shelf	Yes
Number of fruit and vegetables drawers	1	Type of crisper/vegetable drawers cover	Glass
Shelves material	Glass	Low temperature compartment	Yes
Type of crisper/vegetable drawers cover	On sliding rails	Internal light in fridge	Yes
Crisper Cover	Yes	Type of internal light (fridge)	LED

Refrigerator Inner Door

Number of adjustable door shelves	2	No. of bottle shelves	1
-----------------------------------	---	-----------------------	---

Other Refrigerator features



Accessories Egg tray MultiFlow Yes

Freezer compartment features

Number of drawers 3

Other Freezer features

Accessories 1 ice box

Other technical features



Functions display	Fast freezing, ECO
Door open alarm	Yes
Temperature Alarm	Yes
Type of temperature control	Electronic
No. of compressors	1
Refrigerant gas type	R600a
Type of compressor	Standard
Foam agent	Cyclopentane

Performance / Energy Label



Annual energy consumption	242 kWh/year	Noise level	38 dB(A) re 1 pW
Energy efficiency class	E	Thaw time	10 h
Airborne acoustical noise emission class	C	4 star - Freezing capacity	10,0 kg/24h
Total volume	300 l	Climatic class	SN, N, ST, T
Sum of the volumes of the frozen compartment(s)	96 l	EEl	100 %
Sum of the volumes of the chill compartment(s) and the unfrozen compartment(s)	204 l		

Electrical Connection

Nominal power	70 W	Frequency (Hz)	50 Hz
---------------	------	----------------	-------

Current	10 A	Power supply cable length	200 cm
Voltage (V)	220-240 V	Plug	(F;E) Schuko







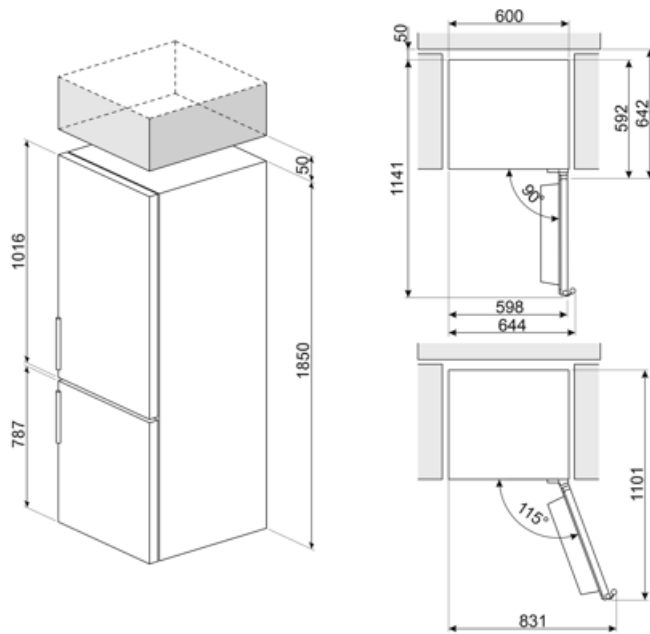

Logistic Information

Width (mm) 600 mm
Depth without handle 592 mm

Product Height with feet 1850 mm



Symbols glossary

- | | | | |
|--|--|---|--|
|  | 4 stars freezing compartment for better food preservation. |  | The automatic defrost system works by automatically defrosting at regular intervals eliminating the need to defrost altogether. |
|  | A++: Energy efficiency class A++ helps to save up to 20% energy compared to class A. Maximum performance with minimum consumption is guaranteed. |  | Energy efficiency class E |
|  | LED display: to show programmes, functions and options selected and the time to the end of the cycle. |  | Economical mode: Analyzes fridge functioning during the activation and optimizes the operating cycle in order to reduce power consumption. |
|  | Fast freezing: The fast freezing function brings the temperature of the compartment down when activated a few hours prior to usage. |  | LED interior lighting: is a more energy efficient and long lasting way of illuminating the interior of the appliance. |
|  | Air plus: keeps food fresher for longer. | | |