

FD70EN4HX



Product Family	Refrigerator
Installation	Free Standing
Category	Double Door
Reference width	60 - 70
Sistema Total No - Frost	Total
Cooling type	Total sem geadas - Sistema de arrefecimento duplo
Defrost	Automatic
Hinge type	Standard
Door opening flush with the wall	No
Slot-in	Yes
Hinge position	Right
Reversible door	Yes
EAN code	8017709295967



Aesthetics



Aesthetic	Universal	Logo colour	Chrome
Colour	Stainless steel	Side material	Steel
Acabamento	Anti-dedadas	Side colour	Silver
Design	Flat	Logotipo	Logotipo aplicado
Material	Stainless steel	Display	LCD
Door steel type	Finger proof	Mostrar porções	Externo (na porta)
Handle kit to be ordered separately	No	Dispenser	No
Handle	External	Water Filter	No
Handle type	Fixed	HomeBar	No
Handle colour	Silver		

Refrigerator compartment features



No. of adjustable shelves	2	Bottle shelf	No
Number of fruit and vegetables drawers	2	Type of crisper/vegetable drawers cover	Glass
Type of adjustable shelves	Glass	Life Plus zone-0°C	Yes
Type of crisper/vegetable drawers cover	Standard	Internal light in fridge	Yes
Crisper Cover	Yes	Type of internal light (fridge)	LED

Refrigerator Inner Door

Number of adjustable door shelves	3	No. of bottle shelves	1
Adjustable door shelves with wire support	No	Bottle shelves with wire support	No

Other Refrigerator features



Accessories	Cheese box, Egg tray	MultiFlow Fan	Yes
Natural Plus Blu Light	No		Yes

Freezer compartment features

No. of shelves	1	Type of internal light (freezer)	LED
Internal light in freezer	Yes	Type of shelves	Glass

Freezer Inner Door

No. of adjustable door shelves	2	Pizza box	No
--------------------------------	---	-----------	----

Other Freezer features

Manual ice maker	Yes	Fast freezing compartment	No
Ice maker	Manual	Ice tray shelf	No

Other technical features



Functions display	Holiday, Fast freezing, Fast cooling, ECO, Control lock, Temperature alarm, Cooling timer
MultiZone	No
Door open alarm	Yes
Temperature Alarm	Yes
Antibacterial Gasket	No
Type of temperature control	Electronic
No. of compressors	1
Refrigerant gas type	R600a
Type of compressor	Inverter
Refrigerant Quantity (gr)	63 g

Etiqueta de Desempenho / Energia - Reg. 2019







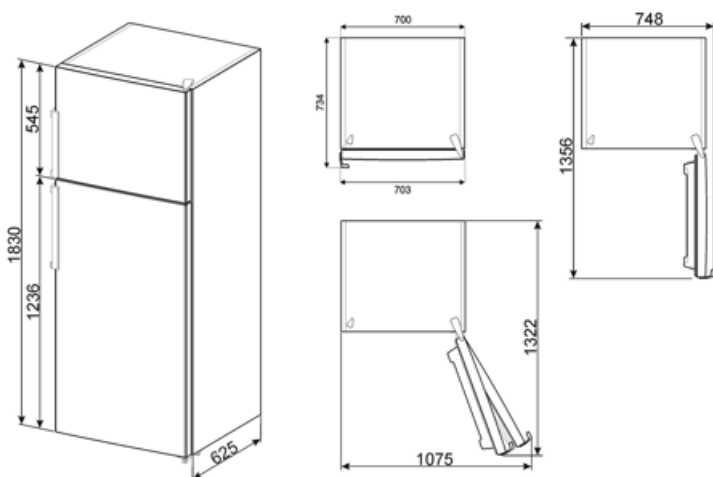









			
Consumo de energia anual	249 kWh/a	Airborne acoustical noise emissions	41 dB(A) re 1 pW
Classe de eficiência energética	E	Autonomia de conservação sem energia elétrica	13.45 h
Classe de emissão de ruído acústico aerotransportado	C	4 estrelas - Capacidade de congelamento	7.0 Kg/24h
Volume líquido total	434 l	Classe climática	SN, T
Soma dos volumes do(s) compartimento(s) congelado(s)	98 l	EEl	100 %
Soma dos volumes do(s) compartimento(s) refrigerado(s) e do(s) compartimento(s) não congelado(s)	337 l		

Electrical Connection

Plug	(F;E) Schuko	Voltage (V)	220-240 V
Electrical connection rating	200 W	Frequency (Hz)	50 Hz
Current	1,39 A	Power supply cable length	210 cm



Symbols glossary

-  Compartimento de congelamento de 4 estrelas para uma melhor preservação dos alimentos.
-  O sistema de descongelamento automático funciona descongelando automaticamente em intervalos regulares, eliminando a necessidade de descongelar completamente.
-  Display LCD: para otimizar o desempenho e simplificar o uso do aparelho.
-  Ventilado: Distribuição forçada de ar frio no compartimento da geladeira, o que permite uma distribuição uniforme da temperatura dentro da geladeira.
-  Aço inoxidável à prova de dedadas: O aço inoxidável à prova de dedadas mantém o aço inoxidável com um aspeto novo.
-  Iluminação interior LED: é uma forma mais eficiente em termos energéticos e duradoura de iluminar o interior do aparelho.
-  Tecnologia do inversor: A evolução dos secadores Smeg para modelos mais inteligentes e ambientalmente sustentáveis levou à escolha do uso da tecnologia do inversor com bombas de calor, o que reduz significativamente o consumo de energia.
-  Slot-in: As geladeiras com abertura Slot-in podem ser perfeitamente integrados na estrutura do mobiliário, uma vez que as portas abertas a 90° não vão além do lado do produto. Em caso de instalação ao lado da parede, será necessário considerar as dimensões do puxador para abrir a porta a 90°.
-  A++: A classe de eficiência energética A++ ajuda a economizar até 20% de energia em comparação com a classe A. O desempenho máximo com consumo mínimo é garantido.
-  Bloqueio para crianças: alguns modelos estão equipados com um dispositivo para bloquear o programa/ciclo para que não possa ser acidentalmente alterado.
-  Modo económico: Analisa o funcionamento da geladeira durante a ativação e otimiza o ciclo de funcionamento, a fim de reduzir o consumo de energia.
-  CONGELAMENTO RÁPIDO: A função de congelamento rápido reduz a temperatura do compartimento quando ativado algumas horas antes do uso.
-  Modo de economia de energia: O modo de economia de energia permite-lhe desativar a geladeira e manter o congelador a funcionar.
-  Life Plus 0°C: A temperatura nos compartimentos Lifeplus é mantida a 0°C, o que preserva a carne fresca e o peixe por mais tempo.
-  Ar mais: mantém a comida mais fresca por mais tempo.
-  Classe de eficiência energética E.

Benefit (TT)

No-Frost system

The No Frost system prevents the formation of ice and contributes to better preservation of food in the refrigerator

Plastic multiflow system

The Multiflow system ensures even distribution of cold air inside the refrigerator

Fan

The fan contributes to an even distribution of air inside the refrigerator

Refrigerant gas R600a

Environmentally friendly R600a refrigerant gas contributes to rapid cooling with lower energy consumption

Climate class

Climatic class SN-T makes the appliance suitable for working at room temperature between 10 °C and 43 °C (50 °F ~ 109 °F)

External handle

The external handle ensures practicality and ease of use of the refrigerator

Life Plus 0°

Temperature-controlled Life Plus compartment for optimal storage of specific food categories

Refrigerator Internal lighting

Interior lighting for perfect visibility of shelves in the refrigerator compartment

Freezer internal lighting

Interior lighting for perfect visibility of the drawers in the freezer compartment

Fruit and vegetable drawer

The fruit and vegetable drawer ensures the best storage conditions for fresh food, avoiding any contamination

Inverter compressor

Inverter compressor reduces noise and vibration levels for a quiet and comfortable kitchen environment

Inverter compressor technology offers significant advantages for refrigeration systems, improving both performance and efficiency. Better temperature control ensures a more stable and constant indoor environment, preserving the freshness of food. This technology also results in reduced energy consumption, as the compressor adjusts its speed according to cooling needs.

Manual Ice Maker

Manual ice maker to manually adjust the amount of ice produced according to personal requirements

External display

External display for simple and intuitive control with quick access to information