

FD70FN1HM



Product Family	Refrigerator
Installation	Free standing
Category	Top Mount
Reference width	60 - 70
Sistema Total No - Frost	Total
Cooling type	Total No Frost - Double Cooling system
Defrost	Automatic
Hinge type	Standard
Slot-in	Yes
Hinge position	Right
Reversible door	Yes
EAN code	8017709295974



Aesthetics

Aesthetic	Universale	Logo colour	Chrome
Colour	Marble look	Side material	Steel
Design	Flat	Side colour	Cream
Material	Metal sheet	Logo	Applied
Handle	External	Alternative colours available	Stainless steel, Silver
Handle type	Fixed	Available colours	FD43PXNF4, FD43PSNF4
Handle colour	Cream		

Refrigerator compartment features



No. of adjustable shelves	2	Type of crisper/vegetable drawers cover	Glass
Number of fruit and vegetables drawers	2	Life Plus zone-0°C	Yes
Type of adjustable shelves	Glass	Internal light in fridge	Yes
Type of crisper/vegetable drawers cover	Standard	Type of internal light (fridge)	LED
Crisper Cover	Yes		

Refrigerator Inner Door

Number of adjustable door shelves	3	No. of bottle shelves	1
-----------------------------------	---	-----------------------	---

Other Refrigerator features



Accessories	Cheese box, Egg tray	Fan	Yes
MultiFlow	Yes		

Freezer compartment features

No. of shelves	1	Type of shelves	Glass
----------------	---	-----------------	-------

Freezer Inner Door

No. of adjustable door shelves	2
--------------------------------	---

Other Freezer features

Manual ice maker	Yes	Ice maker	Manual
------------------	-----	-----------	--------

Other technical features

Type of temperature control	Electro-mechanical
No. of compressors	1
Refrigerant gas type	R600a
Type of compressor	Standard
Refrigerant Quantity (gr)	61 g
Foam agent	Cyclopentane

Performance / Energy Label NEW 2019







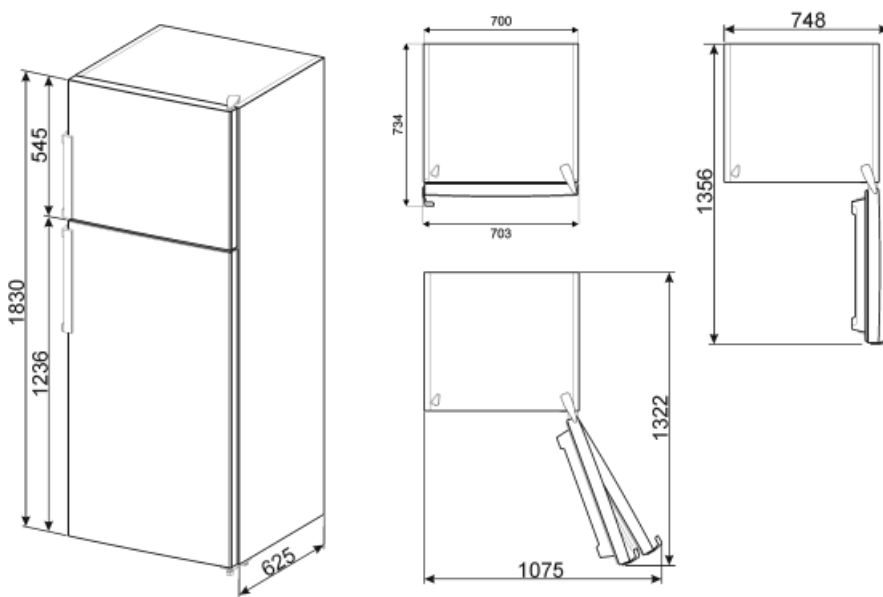

			
Annual energy consumption	311 kWh/a	Airborne acoustical noise emissions	41 dB(A) re 1 pW
Energy efficiency class	F	Temperature Rise Time	13.28 h
Airborne acoustical noise emission class	C	4 star - Freezing capacity	7.0 Kg/24h
Total net volume	434 l	Climate class	SN, T
Sum of the volumes of the frozen compartment(s)	98 l	EEl	125 %
Sum of the volumes of the chill compartment(s) and the unfrozen compartment(s)	337 l		

Electrical Connection

Plug	(F;E) Schuko	Voltage (V)	220-240 V
Electrical connection rating	200 W	Frequency (Hz)	50 Hz
Current	1.39 A	Power supply cable length	210 cm



Symbols glossary (TT)

-  4 stars freezing compartment for better food preservation.
-  The automatic defrost system works by automatically defrosting at regular intervals eliminating the need to defrost altogether.
-  LED interior lighting: is a more energy efficient and long lasting way of illuminating the interior of the appliance.
-  Multiflow Cooling System: the Multiflow ventilation system allows an even distribution of cool air around the fridge cabinet.
-  Energy efficiency class F
-  A+: Energy efficiency class A+ helps to save up to 10% energy compared to class A. Maximum performance with minimum consumption is guaranteed.
-  Ventilated: Forced distribution of cold air in the refrigerator compartment, which allows even temperature distribution within the fridge.
-  Life Plus 0°C: The temperature in the Lifeplus compartments is kept at 0°C, which preserves fresh meat and fish longer.
-  Slot-in: The refrigerators with Slot-in opening can be perfectly integrated into the furniture structure, as the doors open at 90° do not go beyond the side of the product. In case of installation next to the wall, it will be necessary to consider the dimensions of the handle in order to open the door at 90°.