

FF08EW

Product Family	Freezers
Installation	Free Standing
Category	Under counter
Reference width	Until 60
Reference height	160 - 200
Cooling type	Static
Hinge type	Standard
Hinge position	Right
Reversible door	Yes



Aesthetics

Aesthetic	Universale	Handle type	Fixed
Colour	White	Side material	Metal
Design	Flat	Side colour	White
Material	Steel	Logo	Applied
Handle	External	Drawers profile color	Bianco

Freezer compartment features

Number of drawers	3
-------------------	---

Other Freezer features

Ice tray shelf	Yes
----------------	-----

Other technical features

Freezer compartment accessories	Ice cube tray	Refrigerant gas type	R600a
Type of temperature control	Electro-mechanical	Type of compressor	Standard
No. of compressors	1	Foam agent	Cyclopentane

Performance / Energy Label - Reg. 2019



Annual energy consumption	160 kWh/a	Temperature Rise Time	12.10 h
Total net volume	63 l	4 star - Freezing capacity	3.3 Kg/24h
Energy efficiency class	E	Climate class	SN, T
Airborne acoustical noise emission class	C	EI	100 %
Sum of the volumes of the frozen compartment(s)	64 l		

Electrical Connection

Plug	(F;E) Schuko	Voltage	220-240 V
Electrical connection rating	119 W	Frequency (Hz)	50 Hz
Current	0,76 A		

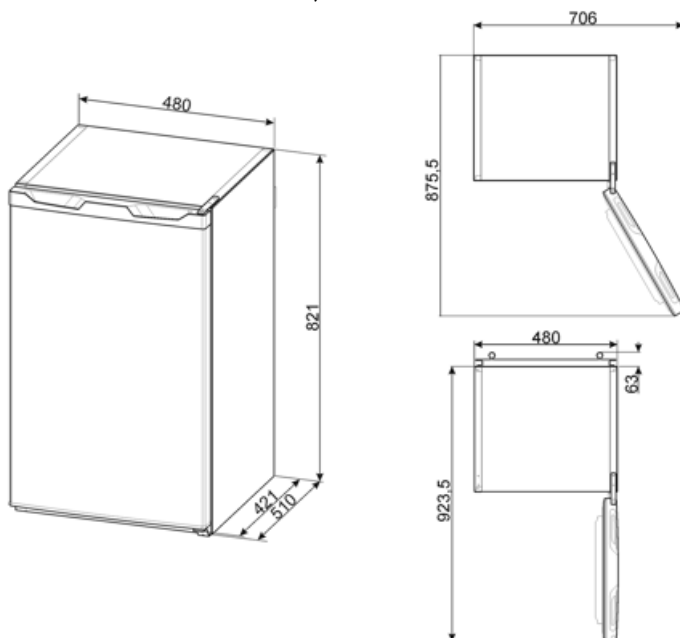

Symbols glossary (TT)



4 stars freezing compartment for better food preservation.



Energy efficiency class E