

# FQ60XDAIF



Product Family	Refrigerator
Installation	Free standing
Category	4 Doors
Reference width	Higher than 80 cm
Sistema Total No - Frost	Total
Cooling type	Total No Frost - Triple Cooling system
Defrost	Automatic
Hinge type	Standard
EAN code	8017709293314



## Aesthetics



Aesthetic	Universale	Logo colour	Chrome
Colour	Inox Look	Side material	Steel
Design	Flat	Side colour	Silver
Finishing	Fingerproof	Logo	Applied
Material	Steel Effect	Door shelves profile color	Silver
Door steel type	Finger proof	Drawers profile color	Silver
Handle	External	Color of glass shelf profile	Silver
Handle type	Fixed	Display	LED
Handle colour	Stainless steel	Display position	Esterno (su porta)

## Refrigerator compartment features



No. of adjustable shelves	2	Type of crisper/vegetable drawers cover	Glass
Number of fruit and vegetables drawers	2	Life Plus zone-0°C	Yes
Shelves material	Glass	Internal light in fridge	Yes
Type of crisper/vegetable drawers cover	On sliding rails	Type of internal light (fridge)	LED
Crisper Cover	Yes		

## Refrigerator Inner Door

No. of door shelves with transparent cover 2  
 Number of adjustable door shelves 2

No. of bottle shelves 2

## Other Refrigerator features



Accessories Egg tray  
 Natural Plus Blu Light Yes  
 MultiFlow Yes

Fan Ionizer Yes  
 Antibacterial odour filter Yes

## Freezer compartment features

Number of drawers 3  
 No. of shelves 2  
 Internal light in freezer Yes

Type of internal light (freezer) LED  
 Type of shelves Glass

## Freezer Inner Door

No. of adjustable door shelves 2

## Other Freezer features



Ice maker Automatic with water tank

Fast freezing compartment Yes

## Other technical features

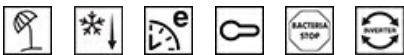

Functions display Holiday, Fast freezing, Fast cooling, ECO, Control lock  
 MultiZone Yes  
 Fast freezing button Yes  
 Temperature alarm lamp Yes  
 Door open alarm Acoustic and visual  
 Temperature Alarm Acoustic and visual  
 Antibacterial Gasket Yes  
 Type of temperature control Electronic  
 No. of compressors 1  
 Refrigerant gas type R600a  
 Type of compressor Inverter  
 Refrigerant Quantity (g) 77 g

## Performance / Energy Label - Reg. 2019

			
<b>Annual energy consumption</b>	414 kWh/a	<b>Airborne acoustical noise emissions</b>	39 dB(A) re 1 pW
<b>Energy efficiency class</b>	F	<b>Temperature Rise Time</b>	10 h
<b>Airborne acoustical noise emission class</b>	C	<b>4 star - Freezing capacity</b>	4.6 kg/24h
<b>Total net volume</b>	572 l	<b>Climate class</b>	SN, T
<b>Sum of the volumes of the frozen compartment(s)</b>	196 l	<b>EEl</b>	125 %
<b>Sum of the volumes of the chill compartment(s) and the unfrozen compartment(s)</b>	376 l		

## Electrical Connection







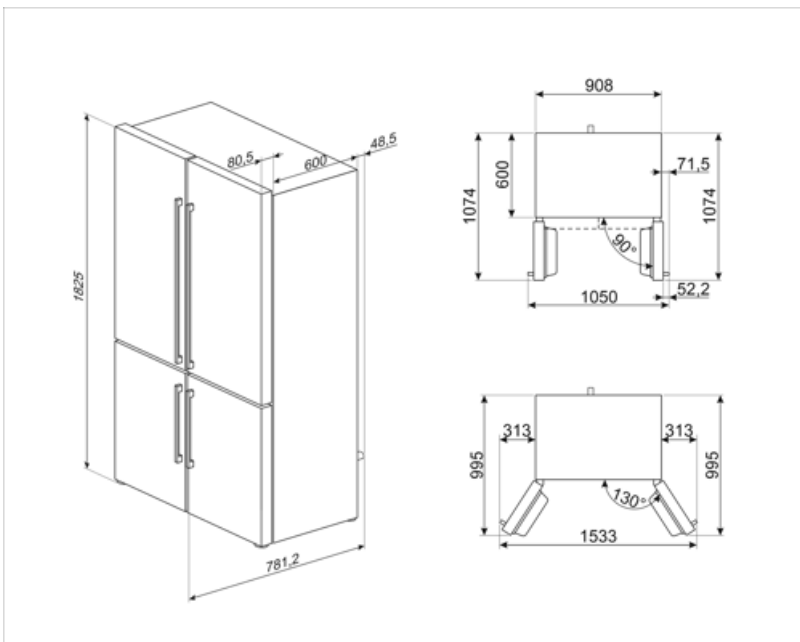











<b>Electrical connection rating</b>	200 W	<b>Frequency (Hz)</b>	50 Hz
<b>Current</b>	0.8 A	<b>Power supply cable length</b>	240 cm
<b>Voltage (V)</b>	230 V	<b>Plug</b>	(F;E) Schuko

## Logistic Information

<b>Width</b>	908 mm	<b>Height</b>	1820 mm
<b>Depth without handle</b>	705 mm	<b>Product width with maximum doors opening</b>	1634 mm



## Symbols glossary

 <p>4 stars freezing compartment for better food preservation.</p>	 <p>Smeg Active Ion system improves the quality of the air inside the cell. Thanks to the generation of negatively charged ions released inside the fridge Active Ion system neutralizes unpleasant dust.</p>
 <p>A++: Energy efficiency class A++ helps to save up to 20% energy compared to class A. Maximum performance with minimum consumption is guaranteed.</p>	 <p>The automatic defrost system works by automatically defrosting at regular intervals eliminating the need to defrost altogether.</p>
 <p>Antibacterial treatment: antibacterial treatment to ensure better hygiene.</p>	 <p>Child lock: some models are fitted with a device to lock the programme/cycle so it cannot be accidentally changed.</p>
 <p>LED display: to show programmes, functions and options selected and the time to the end of the cycle.</p>	 <p>Economical mode: Analyzes fridge functioning during the activation and optimizes the operating cycle in order to reduce power consumption.</p>
 <p>Ventilated: Forced distribution of cold air in the refrigerator compartment, which allows even temperature distribution within the fridge.</p>	 <p>Fast freezing: The fast freezing function brings the temperature of the compartment down when activated a few hours prior to usage.</p>
 <p>Fingerprint proof stainless steel: Fingerprint proof stainless steel keeps stainless steel looking as good as new.</p>	 <p>Power saving mode: The power saving mode allows you to disable the refrigerator and keep the freezer working.</p>
 <p>LED interior lighting: is a more energy efficient and long lasting way of illuminating the interior of the appliance.</p>	 <p>Life Plus 0°C: The temperature in the Lifeplus compartments is kept at 0°C, which preserves fresh meat and fish longer.</p>
 <p>Smeg's evolution towards more intelligent and eco-friendly models has led to the choice of Inverter technology, which significantly reduces consumption.</p>	 <p>Multiflow Cooling System: the Multiflow ventilation system allows an even distribution of cool air around the fridge cabinet.</p>
 <p>Natural Plus Blu Light: This unique Natural Plus Blu Light system works with nature to increase the storage time of fruit and vegetables.</p>	 <p>Energy efficiency class F</p>