

# FQ60XDF



<b>Product Family</b>	Refrigerator
<b>Installation</b>	Free standing
<b>Category</b>	4 Doors
<b>Reference width</b>	Higher than 80 cm
<b>Sistema Total No - Frost</b>	Total
<b>Cooling type</b>	Total No Frost - Double Cooling system
<b>Defrost</b>	Automatic
<b>Hinge type</b>	Standard
<b>EAN code</b>	8017709293307



## Aesthetics



<b>Aesthetic</b>	Universale	<b>Side material</b>	Steel
<b>Colour</b>	Inox Look	<b>Side colour</b>	Silver
<b>Design</b>	Flat	<b>Logo</b>	Applied
<b>Finishing</b>	Fingerproof	<b>Door shelves profile color</b>	Silver
<b>Material</b>	Steel Effect	<b>Drawers profile color</b>	Silver
<b>Door steel type</b>	Finger proof	<b>Color of glass shelf profile</b>	Silver
<b>Handle</b>	External	<b>Display</b>	LED
<b>Handle type</b>	Fixed	<b>Display position</b>	Esterno (su porta)
<b>Handle colour</b>	Stainless steel	<b>Alternative colours available</b>	White, Black
<b>Logo colour</b>	Chrome		

## Refrigerator compartment features



<b>No. of adjustable shelves</b>	2	<b>Type of crisper/vegetable drawers cover</b>	Glass
<b>Number of fruit and vegetables drawers</b>	2	<b>Life Plus zone-0°C</b>	Yes
<b>Shelves material</b>	Glass	<b>Internal light in fridge</b>	Yes
<b>Type of crisper/vegetable drawers cover</b>	On sliding rails	<b>Type of internal light (fridge)</b>	LED
<b>Crisper Cover</b>	Yes		

## Refrigerator Inner Door

No. of door shelves with transparent cover	2	No. of bottle shelves	2
Number of adjustable door shelves	2		

## Other Refrigerator features



Accessories	Egg tray	Fan	Yes
Natural Plus Blu Light	Yes	Ionizer	Yes
MultiFlow	Yes	Antibacterial odour filter	Yes

## Freezer compartment features

Number of drawers	3	Type of internal light (freezer)	LED
No. of shelves	2	Type of shelves	Glass
Internal light in freezer	Yes		

## Other Freezer features



Ice maker	Manual	Fast freezing compartment	Yes
-----------	--------	---------------------------	-----

## Other technical features

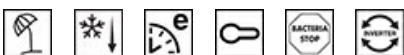

Functions display	Holiday, Fast freezing, Fast cooling, ECO, Control lock
Fast freezing button	Yes
Temperature alarm lamp	Yes
Door open alarm	Yes
Temperature Alarm	Yes
Antibacterial Gasket	Yes
Type of temperature control	Electronic
No. of compressors	1
Refrigerant gas type	R600a
Type of compressor	Inverter
Refrigerant Quantity (g)	72 g
Foam agent	Cyclopentane

## Performance / Energy Label - Reg. 2019

<b>Annual energy consumption</b>	406 kWh/a	<b>Airborne acoustical noise emissions</b>	39 dB(A) re 1 pW
<b>Energy efficiency class</b>	F	<b>Temperature Rise Time</b>	10 h
<b>Airborne acoustical noise emission class</b>	C	<b>4 star - Freezing capacity</b>	4.6 kg/24h
<b>Total net volume</b>	541 l	<b>Freezer (4-star) (1) - Freezing capacity</b>	4.6 kg/24h
<b>Sum of the volumes of the frozen compartment(s)</b>	165 l	<b>Climate class</b>	SN, T
<b>Sum of the volumes of the chill compartment(s) and the unfrozen compartment(s)</b>	376 l	<b>EI</b>	125 %

## Electrical Connection







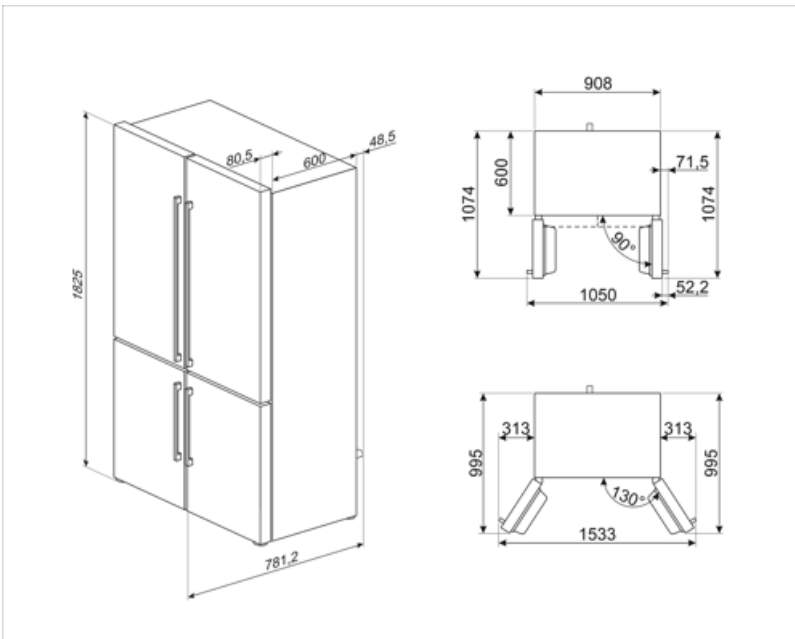











<b>Electrical connection rating</b>	200 W	<b>Frequency (Hz)</b>	50 Hz
<b>Current</b>	0.8 A	<b>Power supply cable length</b>	240 cm
<b>Voltage (V)</b>	230 V	<b>Plug</b>	(F;E) Schuko

## Logistic Information

<b>Width</b>	908 mm	<b>Product width with maximum doors opening</b>	1634 mm
<b>Depth without handle</b>	705 mm	<b>Product depth with handle</b>	750 mm
<b>Height</b>	1820 mm		



## Symbols glossary

 <p>4 stars freezing compartment for better food preservation.</p>	 <p>Smeg Active Ion system improves the quality of the air inside the cell. Thanks to the generation of negatively charged ions released inside the fridge Active Ion system neutralizes unpleasant dust.</p>
 <p>A+: Energy efficiency class A+ helps to save up to 10% energy compared to class A. Maximum performance with minimum consumption is guaranteed.</p>	 <p>The automatic defrost system works by automatically defrosting at regular intervals eliminating the need to defrost altogether.</p>
 <p>Antibacterial treatment: antibacterial treatment to ensure better hygiene.</p>	 <p>Child lock: some models are fitted with a device to lock the programme/cycle so it cannot be accidentally changed.</p>
 <p>LED display: to show programmes, functions and options selected and the time to the end of the cycle.</p>	 <p>Economical mode: Analyzes fridge functioning during the activation and optimizes the operating cycle in order to reduce power consumption.</p>
 <p>Ventilated: Forced distribution of cold air in the refrigerator compartment, which allows even temperature distribution within the fridge.</p>	 <p>Fast freezing: The fast freezing function brings the temperature of the compartment down when activated a few hours prior to usage.</p>
 <p>Fingerprint proof stainless steel: Fingerprint proof stainless steel keeps stainless steel looking as good as new.</p>	 <p>Power saving mode: The power saving mode allows you to disable the refrigerator and keep the freezer working.</p>
 <p>LED interior lighting: is a more energy efficient and long lasting way of illuminating the interior of the appliance.</p>	 <p>Life Plus 0°C: The temperature in the Lifeplus compartments is kept at 0°C, which preserves fresh meat and fish longer.</p>
 <p>Smeg's evolution towards more intelligent and eco-friendly models has led to the choice of Inverter technology, which significantly reduces consumption.</p>	 <p>Multiflow Cooling System: the Multiflow ventilation system allows an even distribution of cool air around the fridge cabinet.</p>
 <p>Natural Plus Blu Light: This unique Natural Plus Blu Light system works with nature to increase the storage time of fruit and vegetables.</p>	 <p>Energy efficiency class F</p>