

# FQ960BL6



Product Family	Refrigerator
Installation	Free Standing
Category	4 Doors
Reference width	Higher than 80 cm
Reference height	160 - 200 cm
No-Frost system	Yes
Cooling type	Total No Frost - Double Cooling system
Defrost	Automatic
EAN code	8017709341503



## Aesthetics



Aesthetics	Victoria	Side material	Steel
Colour	Black	Side colour	Glossy Black
Design	Flat	Logo	Applied
Material	Metal sheet	Door shelves profile colour	Silver
Handle	External	Drawers profile colour	Silver
Handle type	Fixed	Colour of glass shelf profile	Chrome
Handle colour	Chrome	Display	LED
Logo colour	Chrome	Display position	Interior (on the top)

## Refrigerator compartment features



Number of compartments	3	Crisper Cover	Yes
Compartment types	Low temperature compartment, Fruit and vegetable compartment	Type of crisper/vegetable drawers cover	Glass
No. of adjustable shelves	2	Low temperature compartment	Yes
Number of fruit and vegetables drawers	2	Internal light in fridge	Yes
Shelves material	Glass	Type of internal light (fridge)	LED

Type of crisper/vegetable drawers cover Standard

## Refrigerator Inner Door

No. of door shelves with transparent cover 2  
 No. of bottle shelves 2  
 Number of adjustable door shelves 2

## Other Refrigerator features



Humidity Control Yes  
 Accessories Egg tray  
 Natural Plus Blu Light Yes  
 MultiFlow Fan Yes

## Freezer compartment features

Number of drawers 4  
 No. of shelves 2  
 Type of shelves Glass

## Other Freezer features



Fast freezing compartment Yes

## Other technical features



Functions display Holiday, Fast freezing, Fast cooling, ECO  
 Fast freezing button Yes  
 Door open alarm Yes  
 Type of temperature control Electronic  
 No. of compressors 1  
 Refrigerant gas type R600a  
 Type of compressor Inverter  
 Refrigerant Quantity (g) 62 g  
 Foam agent Cyclopentane

## Performance / Energy Label



Noise level 37 dB(A) re 1 pW

<b>Annual energy consumption</b>	338 kWh/year	<b>Thaw time</b>	10 h
<b>Energy efficiency class</b>	E	<b>4 star - Freezing capacity</b>	9 kg/24h
<b>Airborne acoustical noise emission class</b>	C	<b>4 star - Freezing capacity</b>	-18 kg/24h
<b>Total volume</b>	572 l	<b>Climatic class</b>	SN, N, ST, T
<b>Sum of the volumes of the frozen compartment(s)</b>	196 l	<b>EI</b>	100 %
<b>Sum of the volumes of the chill compartment(s) and the unfrozen compartment(s)</b>	376 l		

## Electrical Connection

<b>Nominal power</b>	200 W	<b>Frequency (Hz)</b>	50 Hz
<b>Current</b>	1.2 A	<b>Power supply cable length</b>	240 cm
<b>Voltage (V)</b>	220-240 V	<b>Plug</b>	(F;E) Schuko

## Logistic Information

<b>Width (mm)</b>	915 mm	<b>Product width with maximum doors opening</b>	1371 mm
<b>Depth without handle</b>	705 mm	<b>Product depth with handle</b>	755 mm
<b>Product Height with feet</b>	1870 mm	<b>Product depth with doors open at 90°</b>	1095 mm

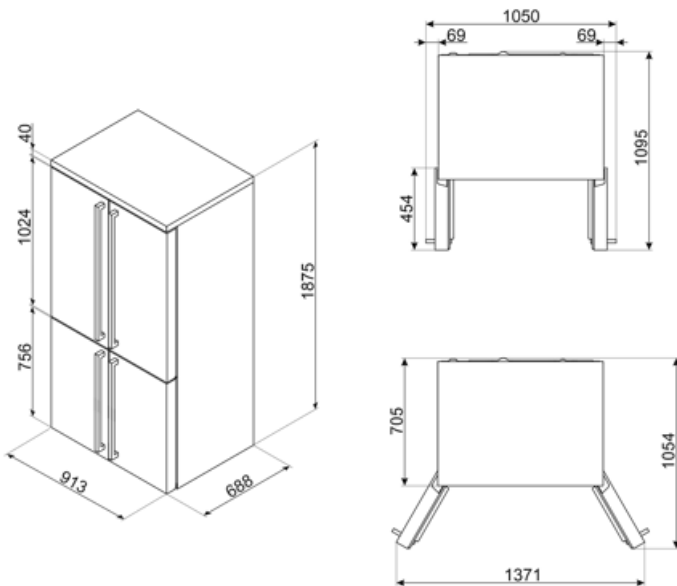

---

## Alternative products

---















**FQ960PB6**  
Pastel Blue



**FQ960P6**  
Cream

## Symbols glossary

	4 stars freezing compartment for better food preservation.		The automatic defrost system works by automatically defrosting at regular intervals eliminating the need to defrost altogether.
	LED display: to show programmes, functions and options selected and the time to the end of the cycle.		Economical mode: Analyzes fridge functioning during the activation and optimizes the operating cycle in order to reduce power consumption.
	Ventilated: Forced distribution of cold air in the refrigerator compartment, which allows even temperature distribution within the fridge.		Fast freezing: The fast freezing function brings the temperature of the compartment down when activated a few hours prior to usage.
	Power saving mode: The power saving mode allows you to disable the refrigerator and keep the freezer working.		LED interior lighting: is a more energy efficient and long lasting way of illuminating the interior of the appliance.
	Inverter technology: The evolution of Smeg's driers towards more intelligent and environmentally sustainable models has led to the choice of using Inverter technology with heat pumps, which reduces significantly energy consumption.		Air plus: keeps food fresher for longer.
	Natural Plus Blu Light: This unique Natural Plus Blu Light system works with nature to increase the storage time of fruit and vegetables.		Energy efficiency class E