

# FQ960PB6



<b>Product Family</b>	Refrigerator
<b>Installation</b>	Free standing
<b>Category</b>	4 Doors
<b>Reference width</b>	Higher than 80 cm
<b>Reference height</b>	160 - 200 cm
<b>Sistema Total No - Frost</b>	Yes
<b>Cooling type</b>	Total No Frost - Double Cooling system
<b>Defrost</b>	Automatic
<b>EAN code</b>	8017709341527



## Aesthetics



<b>Aesthetic</b>	Victoria	<b>Side material</b>	Steel
<b>Colour</b>	Pastel blue	<b>Side colour</b>	Pastel blue
<b>Design</b>	Flat	<b>Logo</b>	Applied
<b>Material</b>	Metal sheet	<b>Door shelves profile color</b>	Silver
<b>Handle</b>	External	<b>Drawers profile color</b>	Silver
<b>Handle type</b>	Fixed	<b>Color of glass shelf profile</b>	Chrome
<b>Handle colour</b>	Chrome	<b>Display</b>	LED
<b>Logo colour</b>	Chrome	<b>Display position</b>	Interno (sul Top)

## Refrigerator compartment features



<b>Number of compartments</b>	3	<b>Crisper Cover</b>	Yes
<b>Compartment types</b>	Low temperature compartment, Fruit and vegetable compartment	<b>Type of crisper/vegetable drawers cover</b>	Glass
<b>No. of adjustable shelves</b>	2	<b>Life Plus zone-0°C Low temperature compartment</b>	Yes
<b>Number of fruit and vegetables drawers</b>	2	<b>Internal light in fridge</b>	Yes
<b>Shelves material</b>	Glass	<b>Type of internal light (fridge)</b>	LED

Type of crisper/vegetable drawers cover Standard

## Refrigerator Inner Door

No. of door shelves with transparent cover 2  
 No. of bottle shelves 2  
 Number of adjustable door shelves 2

## Other Refrigerator features



Humidity Control Yes, manual  
 Accessories Egg tray  
 Natural Plus Blu Light Yes  
 MultiFlow Fan Yes

## Freezer compartment features

Number of drawers 4  
 No. of shelves 2  
 Type of shelves Glass

## Other Freezer features



Fast freezing compartment Yes

## Other technical features



Functions display Holiday, Fast freezing, Fast cooling, ECO  
 Fast freezing button Yes  
 Door open alarm Yes  
 Type of temperature control Electronic  
 No. of compressors 1  
 Refrigerant gas type R600a  
 Type of compressor Inverter  
 Refrigerant Quantity (g) 62 g  
 Foam agent Cyclopentane

## Performance / Energy Label - Reg. 2019



Annual energy consumption	338 kWh/a	Airborne acoustical noise emissions	37 dB(A) re 1 pW
Energy efficiency class	E	Temperature Rise Time	10 h
Airborne acoustical noise emission class	C	4 star - Freezing capacity	9 kg/24h
Total net volume	572 l	Freezer (4-star) (1) - Freezing capacity	-18 kg/24h
Sum of the volumes of the frozen compartment(s)	196 l	Climate class	SN, N, ST, T
Sum of the volumes of the chill compartment(s) and the unfrozen compartment(s)	376 l	EI	100 %

## Electrical Connection

Electrical connection rating	200 W	Frequency (Hz)	50 Hz
Current	1.2 A	Power supply cable length	240 cm
Voltage (V)	220-240 V	Plug	(F;E) Schuko

## Logistic Information

Width	915 mm	Product width with maximum doors opening	1435 mm
Depth without handle	705 mm	Product depth with handle	725 mm
Height	1870 mm	Product depth with doors open at 90°	1085 mm

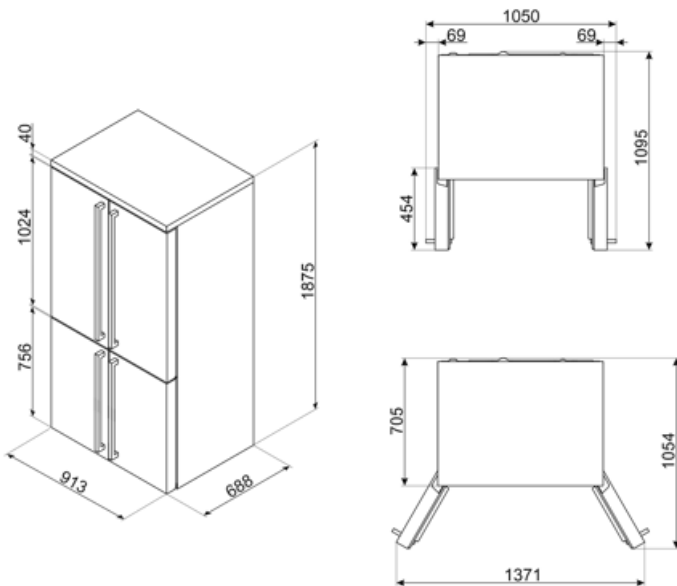

---

## Alternative products

---















**FQ960BL6**  
Black



**FQ960P6**  
Cream

## Symbols glossary

	4 stars freezing compartment for better food preservation.		The automatic defrost system works by automatically defrosting at regular intervals eliminating the need to defrost altogether.
	Energy efficiency class E		LED display: to show programmes, functions and options selected and the time to the end of the cycle.
	Economical mode: Analyzes fridge functioning during the activation and optimizes the operating cycle in order to reduce power consumption.		Ventilated: Forced distribution of cold air in the refrigerator compartment, which allows even temperature distribution within the fridge.
	Fast freezing: The fast freezing function brings the temperature of the compartment down when activated a few hours prior to usage.		Power saving mode: The power saving mode allows you to disable the refrigerator and keep the freezer working.
	LED interior lighting: is a more energy efficient and long lasting way of illuminating the interior of the appliance.		Life Plus 0°C: The temperature in the Lifeplus compartments is kept at 0°C, which preserves fresh meat and fish longer.
	Smeg's evolution towards more intelligent and eco-friendly models has led to the choice of Inverter technology, which significantly reduces consumption.		Multiflow Cooling System: the Multiflow ventilation system allows an even distribution of cool air around the fridge cabinet.
	Natural Plus Blu Light: This unique Natural Plus Blu Light system works with nature to increase the storage time of fruit and vegetables.		