

# FQI48KD



Product Family	Refrigerator
Installation	Free Standing
Category	4 Doors
Reference width	Higher than 80
Reference height	160 - 200
Sistema Total No - Frost	Total
Cooling type	Total No Frost
Defrost	Automatic
Hinge type	Standard
EAN code	8017709346492



## Aesthetics



Aesthetic	Universal	Side material	Steel
Colour	Dark Inox Look	Side colour	Dark grey
Acabamento	Anti-dedadas	Logotipo	Logotipo aplicado
Design	Flat	Cor do perfil das prateleiras da porta	Silver
Material	Metal sheet	Cor do perfil das gavetas	Silver
Door steel type	Finger proof	Cor do perfil da prateleira de vidro	Silver
Handle kit to be ordered separately	No	Display	LED
Handle	Integrated	Mostrar porções	Externo (na porta)
Handle type	Fixed	Dispenser	No
Handle colour	Black	Water Filter	No
Logo colour	Chrome	HomeBar	No

## Refrigerator compartment features



No. of adjustable shelves	2	Nº de lâmpadas	2
Number of fruit and vegetables drawers	1	Life Plus zone-0°C	No
Type of adjustable shelves	Glass	Convertible temperature drawer	No
		Compartimento baixa temperatura	Yes
		Internal light in fridge	Yes
		Type of internal light (fridge)	LED

Type of crisper/vegetable drawers cover Standard

Crisper Cover Yes

Bottle shelf No

Type of crisper/vegetable drawers cover Glass

## Refrigerator Inner Door

Number of adjustable door shelves 4

Adjustable door shelves with wire support No

No. of bottle shelves 2

Bottle shelves with wire support No

## Other Refrigerator features



Humidity Control Yes

Accessories Bottle holder, Egg tray

Natural Plus Blu Light No

MultiFlow Metal

Fan No

Ionizer No

Tecnologia de titânio No

Filtro de odor antibacteriano Yes

## Freezer compartment features

Number of drawers 4

No. of shelves 1

Internal light in freezer No

Type of shelves Glass

## Other Freezer features



Accessories manual ice-maker

Manual ice maker Yes

Ice maker Manual

Fast freezing compartment Yes

Ice tray shelf No

## Other technical features



Functions display Holiday, Fast freezing, Fast cooling, ECO, Control lock, Cooling timer

MultiZone No

Fast freezing button Yes

Ligação à rede de água No

Door open alarm Yes

Type of temperature control	Electronic
No. of compressors	1
Refrigerant gas type	R600a
Type of compressor	Inverter
Espuma expansiva de isolamento	Ciclopentano

## Etiqueta de Desempenho / Energia - Reg. 2019









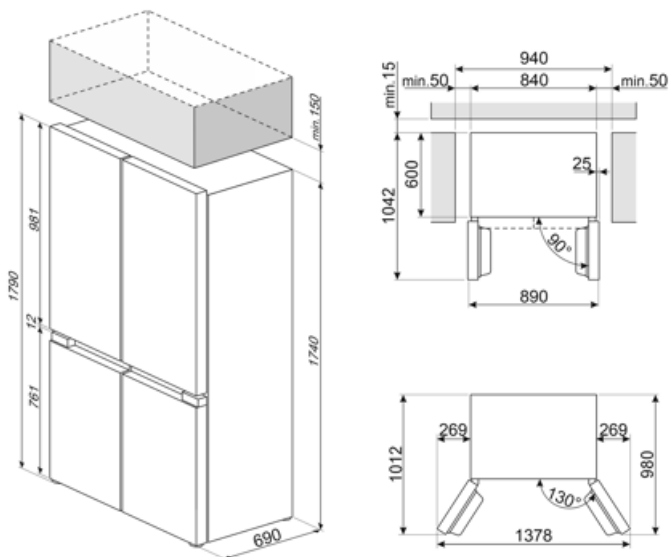



Consumo de energia anual	244 kWh/a	Airborne acoustical noise emissions	39 dB(A) re 1 pW
Classe de eficiência energética	D	Autonomia de conservação sem energia eléctrica	10.8 h
Classe de emissão de ruído acústico aerotransportado	C	4 estrelas - Capacidade de congelamento	8.7 Kg/24h
Volume líquido total	488 l	Classe climática	SN, T
Soma dos volumes do(s) compartimento(s) congelado(s)	166 l	EI	80 %
Soma dos volumes do(s) compartimento(s) refrigerado(s) e do(s) compartimento(s) não congelado(s)	322 l		

## Electrical Connection

Plug	(F;E) Schuko	Voltage (V)	220-240 V
Electrical connection rating	206 W	Frequency (Hz)	50 Hz
Current	1 A	Power supply cable length	250 cm



## Symbols glossary

- |  |   |   |  |
|--|---|---|--|
|    | O sistema de descongelamento automático funciona descongelando automaticamente em intervalos regulares, eliminando a necessidade de descongelar completamente.  |  | Bloqueio para crianças: alguns modelos estão equipados com um dispositivo para bloquear o programa/ciclo para que não possa ser acidentalmente alterado. |
|    | Display LED: para mostrar os programas, funções e opções selecionadas e o tempo até ao final do ciclo.  |  | Modo económico: Analisa o funcionamento da geladeira durante a ativação e otimiza o ciclo de funcionamento, a fim de reduzir o consumo de energia.       |
|    | <b>CONGELAMENTO RÁPIDO:</b> A função de congelamento rápido reduz a temperatura do compartimento quando ativado algumas horas antes do uso.   |  | Aço inoxidável à prova de dedadas: O aço inoxidável à prova de dedadas mantém o aço inoxidável com um aspeto novo.                                       |
|    | Modo de economia de energia: O modo de economia de energia permite-lhe desativar a geladeira e manter o congelador a funcionar.   |  | Iluminação interior LED: é uma forma mais eficiente em termos energéticos e duradoura de iluminar o interior do aparelho.                                |
|    | Tecnologia do inversor: A evolução dos secadores Smeg para modelos mais inteligentes e ambientalmente sustentáveis levou à escolha do uso da tecnologia do inversor com bombas de calor, o que reduz significativamente o consumo de energia. |  | Classe de eficiência energética D  |
|  | Multiflow Cooling System: the Multiflow ventilation system allows an even distribution of cool air around the fridge cabinet. The stainless steel panel gives a more premium look to the appliance.   |   |  |

---

## Benefit (TT)

---

### **No-Frost system**

The No Frost system prevents the formation of ice and contributes to better preservation of food in the refrigerator

### **Metallic Multiflow system**

The metal Multiflow system ensures an even distribution of cold air inside the refrigerator, which diffuses through an elegant stainless steel panel

A back panel with a series of openings ensures uniform circulation of cold air around each shelf of the refrigerator. This advanced air recirculation system ensures a constant temperature and humidity level, preserving food freshness for longer and helping to reduce food waste significantly

### **Refrigerant gas R600a**

Environmentally friendly R600a refrigerant gas contributes to rapid cooling with lower energy consumption

### **Reversible door**

Reversible door ensures flexible installation and space optimisation

### **Refrigerator Internal lighting**

Interior lighting for perfect visibility of shelves in the refrigerator compartment

### **Fruit and vegetable drawer**

The fruit and vegetable drawer ensures the best storage conditions for fresh food, avoiding any contamination

### **Inverter compressor**

Inverter compressor reduces noise and vibration levels for a quiet and comfortable kitchen environment

Inverter compressor technology offers significant advantages for refrigeration systems, improving both performance and efficiency. Better temperature control ensures a more stable and constant indoor environment, preserving the freshness of food. This technology also results in reduced energy consumption, as the compressor adjusts its speed according to cooling needs.

### **Manual Ice Maker**

Manual ice maker to manually adjust the amount of ice produced according to personal requirements

### **External display**

External display for simple and intuitive control with quick access to information