

## FQI60KD



Product familie	Koelkast
Installatie	Vrijstaand
Categorie	Koel-vriescombinatie met 4 deuren
Referentie breedte	Meer dan 80 cm cm
Referentie hoogte	160 - 200 cm cm
No Frost systeem	Ja
Type koelen	No Frost
Ontdooien	Automatisch ontdooien
Type scharnier	Standaard
EAN-code	8017709342128



## Design



Design	Universeel	Materiaal zijwanden	Staal
Kleur	Dark Inox Look	Kleur zijkanten	Zwart
Design	Plat	Logo	Geassembleerd
Afwerking	Fingerproof	Kleur profielen binnenzijde	Zilver
Materiaal deur	Inox look	Kleur profielen laden	Zilver
Handgreep	Geïntegreerd	Kleur profiel glazen leggers	Zilver
Type handgreep	Vast	Display	LED
Kleur handgreep	Zwart	Positie display	Esterno (su porta)
Kleur logo	Chroom		

## Uitrusting koelkast



Number of compartments	3	Aantal lampen	2
Compartment types	Fruit and vegetable compartment, Variable temperature compartment - 3°/0°/3°C	Convertible temperature drawer	Yes
Afdekplaat groentenlade	Ja	Binnenverlichting koelkast	Ja
Type afdekplaat groente-/fruitlade	Glas	Type binnenverlichting koelkast	LED

## Binnendeur koelkast

Aantal verstelbare  
binnendeurcompartimenten 4

Aantal flessenhouders 2

## Overige features koelkast



Humidity Control No

MultiFlow

Metal

## Uitrusting vriezer

Aantal lades 4

Aantal legplanken 2

Aantal lampen 2

Binnenverlichting  
vriezer Ja

Type verlichting vriezer LED

Type leggers Kunststof

## Overige features vriezer



Snel-vriescompartiment Ja

## Overige technische eigenschappen



Display functies

Vakantiefunctie, Snel-vriesfunctie, Snel-koelfunctie,  
MultiZone, ECO

MultiZone

Ja

Snel-vriestoets

Ja

Alarm open deur

Ja

Type temperatuurcontrole

Elektronisch

Aantal compressoren

1

Type koelgas

R600a

Type compressor

Variabele toeren

Schuimmiddel

Cyclopentaan

## Prestaties/Energie label - Reg. 2019



Annual energy  
consumption 255 kWh/jaar

Geluidsniveau 39 dB(A) re 1 pW

Energie-efficiëntieklasse D

Conserveringsduur  
zonder stroom 11 h

Emissieklasse voor  
akoestisch luchtgeluid C

4 star - Freezing  
capacity 13,0 kg/24h

Totaal netto volume 522 l

Klimaatklasse SN, N, ST

Netto inhoud  
vriesgedeelte 179 l

EEl 80 %

Netto inhoud 343 l  
koelgedeeltes

## Elektrische aansluiting







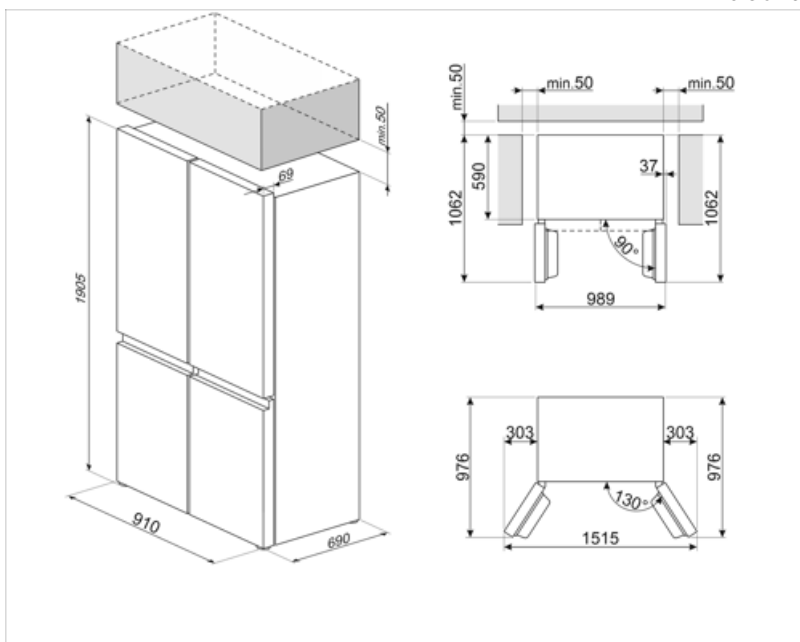



Nominale aansluitwaarde	180 W	Frequentie (Hz)	50 Hz
Stroom (A)	1,5 A	Lengte stroomkabel	180 cm
Spanning (V)	220-240 V	Stekker	(F;E) Schuko

## Logistieke informatie

Breedte product (mm)	909 mm	Product breedte met maximale deuropening	1515 mm
Diepte zonder handvat en spacer	690 mm	Diepte toestel met handvat	690 mm
Maximum hoogte	1900 mm	Diepte toestel met deuren open 90°	1062 mm



## Symbols glossary

	The automatic defrost system works by automatically defrosting at regular intervals eliminating the need to defrost altogether.		Energie-efficiëntieklasse
	LED display: to show programmes, functions and options selected and the time to the end of the cycle.		Economical mode: Analyzes fridge functioning during the activation and optimizes the operating cycle in order to reduce power consumption.
	Fast freezing: The fast freezing function brings the temperature of the compartment down when activated a few hours prior to usage.		Power saving mode: The power saving mode allows you to disable the refrigerator and keep the freezer working.
	LED interior lighting: is a more energy efficient and long lasting way of illuminating the interior of the appliance.		De evolutie van Smeg vaatwassers naar meer intelligente en milieuvriendelijke modellen heeft ertoe geleid om de inverter technologie te gebruiken, die een significante energie- en geluidsbesparing met zich meebrengt.
	Multizone: Multizone compartment can be used as a refrigerator or a freezer compartment. Depending on your needs and eating habits, you can select settings, program the temperature using.		Multiflow Cooling System: the Multiflow ventilation system allows an even distribution of cool air around the fridge cabinet. The stainless steel panel gives a more premium look to the appliance.