

FS09FS

Product Family	Refrigerator
Installation	Free standing
Category	Under counter
Reference width	Until 60
Reference height	Until 100
Cooling type	Static
Hinge type	Standard
Hinge position	Right
Reversible door	Yes
EAN code	8017709296117

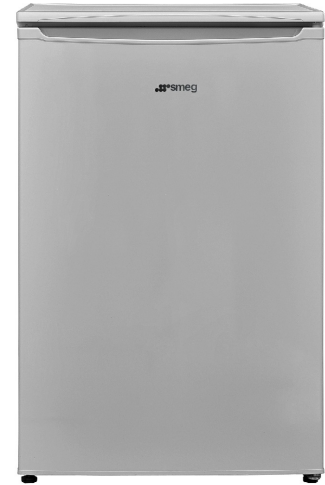

Aesthetics

Aesthetic	Universale	Handle colour	Silver
Colour	Silver	Side material	Steel
Design	Flat	Side colour	Silver
Material	Metal sheet	Logo	Applied
Handle	Integrated	Alternative colours available	White
Handle type	Fixed		

Refrigerator compartment features

No. of adjustable shelves	1	Crisper Cover	Yes
Number of fruit and vegetables drawers	1	Type of crisper/vegetable drawers cover	Glass
Type of adjustable shelves	Glass	Internal light in fridge	Yes
Type of crisper/vegetable drawers cover	Standard	Type of internal light (fridge)	Incandescent light

Refrigerator Inner Door

Number of adjustable door shelves	2	No. of bottle shelves	1
-----------------------------------	---	-----------------------	---

Other Refrigerator features

Accessories Egg tray

Freezer compartment features

Internal freezer compartment Yes

Other technical features

Type of temperature control	Electro-mechanical
No. of compressors	1
Refrigerant gas type	R600a
Refrigerant Quantity (gr)	25 g
Foam agent	Cyclopentane

Performance / Energy Label NEW 2019



Annual energy consumption	181 kWh/a	Airborne acoustical noise emissions	40 dB(A) re 1pW
Energy efficiency class	F	Temperature Rise Time	6.6 h
Airborne acoustical noise emission class	C	4 star - Freezing capacity	2.6 Kg/24h
Total net volume	121 l	Climate class	SN, T
Sum of the volumes of the frozen compartment(s)	17 l	EEl	125 %
Sum of the volumes of the chill compartment(s) and the unfrozen compartment(s)	105 l		

Electrical Connection

Plug	(F;E) Schuko	Voltage (V)	220-240 V
Electrical connection rating	106 W	Frequency (Hz)	50 Hz
Current	0,51 A	Power supply cable length	120 cm

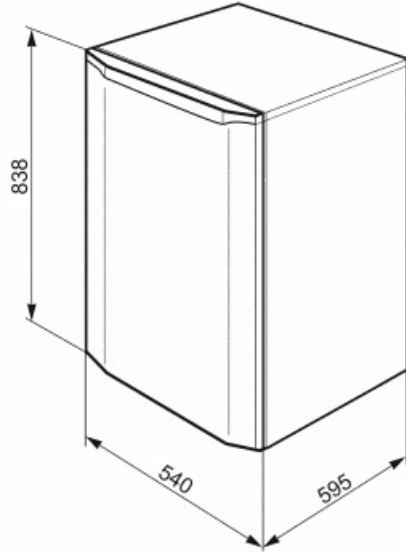

Symbols glossary (TT)



4 stars freezing compartment for better food preservation.



A+: Energy efficiency class A+ helps to save up to 10% energy compared to class A. Maximum performance with minimum consumption is guaranteed.



Energy efficiency class F