

FZU18LX



Product Family	Freezers
Installation	Built-in
Category	Single door
Reference width	Until 60
Reference height	Higher than 200
Cooling type	No Frost
Hinge type	Door on door
Hinge position	Left



Aesthetics

Aesthetic	Universale	Handle colour	Stainless steel
Colour	Stainless steel	Side material	Metal
Material	Stainless steel	Logo	Applied
Door steel type	Normal	Drawers profile color	Silver
Handle	External	Display	TFT
Handle type	Fixed		

Freezer compartment features



Internal light in freezer	Yes
Type of internal light (freezer)	LED
Number of drawers	3

Other Freezer features

Warehouse availability Automatico
first date

Other technical features



Functions display	Holiday, Fast Freezing, MultiZone, Sabbath	Type of temperature control	Electronic
Fast freezing button	Yes		

Power on lamp	Yes	No. of compressors	1
Temperature alarm lamp	Yes	Refrigerant gas type	R600a
Door open alarm	Yes	Type of compressor	Inverter
Temperature alarm	Yes	Refrigerant Quantity (gr)	59 oz
Antibacterial Gasket	Yes	Metal panel on the back of the fridge	Metal

Performance / Energy Label - Reg. 2019

Total net volume	61.3 gal	Climate class	SN, N, ST, T
------------------	----------	---------------	--------------

Electrical Connection

Plug	(B) USA 120V	Frequency (Hz)	60 Hz
Current	2,4 A	Power supply cable length	78 3/4 "
Voltage	115 V		

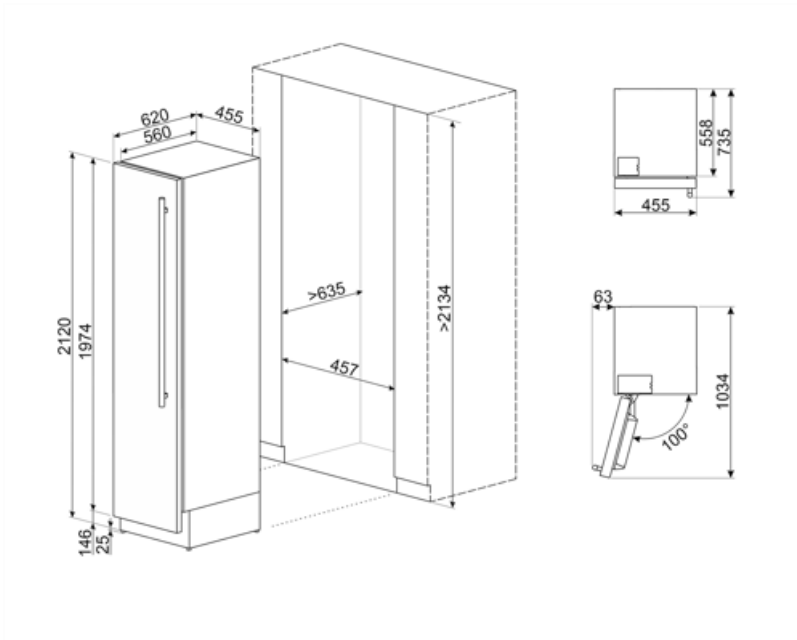

Symbols glossary



Fast freezing: The fast freezing function brings the temperature of the compartment down when activated a few hours prior to usage.



LED interior lighting: is a more energy efficient and long lasting way of illuminating the interior of the appliance.



Multizone: Multizone compartment can be used as a refrigerator or a freezer compartment. Depending on your needs and eating habits, you can select settings, program the temperature using.



Power saving mode: The power saving mode allows you to disable the refrigerator and keep the freezer working.



Smeg's evolution towards more intelligent and eco-friendly models has led to the choice of Inverter technology, which significantly reduces consumption.



No Frost: The No Frost and Frost free systems prevent ice from forming so that no defrosting is required.