

HOB682D1

Product Family	Hob
Built-in type	Ultra-low profile or Fully Flushed
Dimensions	80 cm
Power supply	Electric
Type	Indução com exaustor integrado
Extraction	Extraction
Electronic control	Yes
Perimeter extraction	No
EAN code	8017709298685
Energy efficiency class (EEC)	A+++



Aesthetics



Aesthetic	Universal
Colour	Black
Acabamento	Glass
Material	Glass
Glass type	Ceramic
Glass edge	Straight edge
Glass on Steel	No
Frame	No
Pan stands	Cast iron
Type of control setting	Multi Controle Deslizante
Slider	Yes
Control knob position	Front
Serigraphy colour	Grey
Alternative colours available	No

Program / Functions

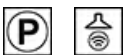

No. of induction cook zones	4
Time-setting options	Spegnimento automatico
No. of cooking zones with booster	4
No. of Flexible zones	2
Main on/off switch	Yes
Power levels	9
Ventilação automática 2.0	Sim

Total no. of cook zones

2

Options



Multizone Option	Yes	Minute minder	1
Tipo de zona flexível	MultiZone	End of cooking alarm	Yes
Corte padrão	482-483x765-766 mm	Residual time indicator	Yes
Auto-boiling Function	No	Limited Power	No
Simmering Function	Yes	Consumption Mode	
Keep warm automatic function	Yes	Showroom Demo Option	No
Melting/Low temperature cooking function	Yes	Control Lock / Child Safety	Yes
End cooking timer	4	Cleaning option	No
Pause option	Yes	Quick start	Yes
		Rapid level selection	Yes

Technical Features



Left - Induction - Multizone - 2.10 kW - Booster 3.70 kW - 23.0x21.0 cm
 Right - Induction - Multizone - 2.10 kW - Booster 3.70 kW - 23.0x21.0 cm
 2.10 kW - Booster 3.70 kW - 23.0x21.0 cm
 2.10 kW - Booster 3.70 kW - 23.0x21.0 cm
 Multizone left - Booster 3.70 kW - 46.0x21.0 cm
 Multizone right - Booster 3.70 kW - 46.0x21.0 cm

Automatic setting according to pan dimension	Yes	Automatic switch off when overflow	Yes
pan detection	Yes	Residual heat indicator	Yes
Detecção Automática Permanente de Pote com indicação do controle relativo	Yes	Protection against accidental start up	Yes
Automatic switch off when overheat	No		

Accessories Included

Tube reduction	No	Remote control	No
Other accessories	No	Tube reduction	No
Sliding door	No		

Electrical Connection

Plug	No	Type of electric cable supplied	Yes, Single and Double phase
Electrical connection rating (W)	7620 W	Frequency (Hz)	50/60 Hz

Current	33 A	Comprimento do cabo de alimentação	120 cm
Voltage (V)	220-240 V	Placa de bornes	6 polos
Voltage 2 (V)	380-415 V	Ficha elétrica	No

Controles (exaustor)

Configuração de controle do exaustor	Capacidade de Toque	Display	Yes
Led color	Bianco		

Programas/Funções (exaustor)

Delay function	Yes	Other functions	AUTOVENT
No. of speeds	8	Configuração do tempo do exaustor	No
Intensive speed	2	Other options	No
24h air filter function	No		

Características técnicas (exaustor)

Remote motor	No	Anti-grease filters	Alluminio
Free outlet maximum capacity	750 m ³ /h	Charcoal filters included	No
Motor power	220 W	Filter replacement indicator	Yes
No. of filters	1	Non return valve	No

Etiqueta de desempenho/Energia (exaustor)

Fluid Dynamic Efficiency (FDE)	40,30	Airborne acoustical A-weighted sound Power Emission at maximum speed (SPEmax)	65 dBA
Fluid Dynamic Efficiency class (FDEC)	A	Airbourne acoustical A-weighted sound power emission at boost speed (SPEboost)	72 dBA
Lighting Efficiency (LE)	0,0 lux/W	Power Consumption in Off mode (Po)	0,49 W
Lighting Efficiency Class (LEC)	NA	Time increase factor (F)	0,5
Grease Filtering Efficiency (GFE)	85,1 %	Energy Efficiency Index	27,5
Grease Filtering Efficiency Class (GFEC)	B	Measured air flow rate at best efficiency point (Qbep)	359 m ³ /h
Air flow at minumum speed (Qmin)	245 m ³ /h	Measured air pressure at best efficiency point (Pbep)	549 Pa
Air flow at maximum speed (Qmax)	505 m ³ /h	Measured electric power input at best efficiency point (Wbep)	136 W
Air flow at boost speed (Qboost)	700 m ³ /h	Sound power level at highest setting (Lwa)	65 dBA
Airbourne acouistical A-weighted sound Power Emission at minimum speed (SPEmin)	51 dBA		

Ligações eléctricas (exaustor)

Frequência do exaustor 50-60 Hz

Speed 1

Extraction rate IEC 61591	245 m ³ /h
Noise level IEC 60704-2-13	51 dBA
Pressure	290 Pa
Power	35 W

Speed 2

Extraction rate IEC 61591	285 m ³ /h
Noise level IEC 60704-2-13	55 dBA
Pressure	370 Pa
Power	45 W

Speed 3

Extraction rate IEC 61591	350 m ³ /h
Noise level IEC 60704-2-13	57 dBA
Pressure	525 Pa
Power	60 W

Speed 4

Extraction rate IEC 61591	380 m ³ /h
Noise level IEC 60704-2-13	59 dBA
Pressure	530 Pa
Power	75 W

Velocidade 5

Extraction rate IEC 61591	410 m ³ /h
Noise level IEC 60704-2-13	62 dBA
Pressure	535 Pa
Power	85 W

Velocidade 6

Extraction rate IEC 61591	445 m ³ /h
Noise level IEC 60704-2-13	63 dBA
Pressure	540 Pa
Power	105 W

Velocidade 7

Extraction rate IEC 61591	475 m ³ /h
Noise level IEC 60704-2-13	64 dBA
Pressure	545 Pa
Power	115 W

Velocidade 8

Extraction rate IEC 61591	505 m ³ /h
Noise level IEC 60704-2-13	65 dBA
Pressure	550 Pa
Power	125 W

Intensive speed

Extraction rate (IEC 61591)	550 m ³ /h
Noise level IEC 60704-2-13	66 dBA
Pressure	555 Pa
Power	140 W

Velocidade Intensiva 2

Extraction rate IEC 61591	700 m ³ /h
Noise level IEC 60704-2-13	72 dBA
Pressure	560 Pa
Power	220 W

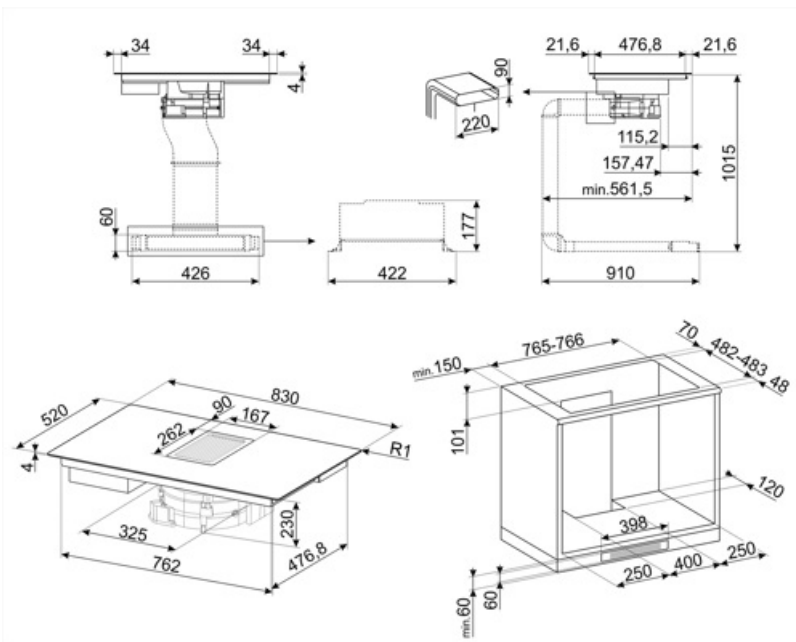

Compatible Accessories



CON60H

Flat duct connector for tubes 220*60 mm. It help to connect more tubes of the kit KITEHOBD4



GRI60H

Rectangular Louvred grille, external size 246*80 mm and internal 226*60*50 mm



KITEHOBD4

Kit de filtragem (saída lateral) opcional para Hobd: tubo 1,5 mt e curva



RED60H

Reducer from 90 to 60 mm suitable for rectangular tube of 220 mm. Size: 220x90x92 mm



FLTHOBD

Filtro cerâmico anti-odor regenerável como peça de reposição adequada para kit de recirculação (acessório KITF6HOBD) da placa com exaustor integrado modelos HOBD682D e HOBD682R



KITEHOBD

Kit de escape opcional para Hobd: tubos para instalação no modo de escape

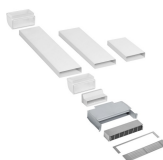

KITF6HOBD



















Kit de recirculação para Hobd: tubos + filtro anti-odor regenerável + grelha em aço inoxidável com fixação magnética (fácil de remover) que se encaixam num plinto de no mínimo 6 cm



TPK

Placa grelhadora de aço inoxidável para cozinhar pratos Teppanyaki

Symbols glossary

	Impulsionador de potência: opção permite que a zona funcione em potência máxima quando é necessário cozinhar muito intensamente.		Suportes de ferro fundido para serviço pesado: para máxima estabilidade e resistência.
	Bloqueio para crianças: alguns modelos estão equipados com um dispositivo para bloquear o programa/ciclo para que não possa ser acidentalmente alterado.		O painel de controle deslizante permite-lhe ajustar a potência simplesmente passando o dedo pelo dispositivo tátil.
	Mantenha a função quente: Mantenha a função quente mantém o alimento cozido aquecido. Neste modo, a zona de aquecimento funciona a uma capacidade mínima de 120 minutos e, em seguida, desliga-se automaticamente.		Função de derretimento, adequado para derreter lentamente alimentos delicados, como chocolate ou manteiga.
	Multizona: permite que várias placas sejam usadas ao mesmo tempo, grandes ou pequenas, oferecendo liberdade de colocação e maior flexibilidade		Proteção especial contra transbordamento: A proteção especial contra transbordamento desliga o fogão na presença de transbordamento de líquidos.
	PAUSE_72dpi		Seleção rápida, com um toque de cozimento começa no nível mais alto, em seguida, reduz automaticamente após o tempo. Ideal para pratos que exigem fervura rápida e, em seguida, cozimento contínuo sem controle constante (por exemplo, caldo de carne).
	Função de arranque rápido: a temperatura escolhida é atingida mais rapidamente. O elemento de aquecimento funciona na potência máxima até que a temperatura certa seja atingida.		Indicação de calor residual: Depois de a placa de cerâmica de vidro ter sido desligada, o indicador de calor residual mostra qual das zonas de aquecimento ainda permanece quente. Quando a temperatura cai abaixo de 60°C, o indicador se apaga.
	Função de cozedura: ideal para receitas de longa duração, impedindo que os alimentos fervam ou grudem na panela.		Tempo decorrido: mostra há quanto tempo a zona de cozedura está em uso.
	Temporizador: Todas as placas de cerâmica têm um temporizador que termina automaticamente o cozimento após um tempo predefinido.		Detecção de pote automático permanente
	Ligação entre a placa e o exaustor		Controle deslizante individual Premium para cada zona