

# KAT120HXE

Product family	Hood
Hood Type	Decorative wall hood
Design	T flat
Extraction	Extraction
Material	Stainless steel
Type of steel	Brushed
EAN code	8017709201555
Hood width	120 cm



## Aesthetics

Aesthetic Colour	Universale Stainless steel	Finishing Logo	Satin Silk screen
------------------	-------------------------------	----------------	----------------------

## Controls

Control setting	Buttons
-----------------	---------

## Technical Features



No. of lights	3	Anti-grease filters	Aluminium
Light type	LED	Filter replacement indicator	Yes
Light Power	8 W	Vent outlet	150 mm
Light color temperature scale (°K)	3500 °K	Minimum distance from GAS hob	650 mm
Free outlet maximum capacity	750 m <sup>3</sup> /h	Minimum distance from ELECTRIC hob	500 mm
Motor power	260 W	Non return valve	Yes
No. of filters	4		

	Extraction rate IEC 61591 [m <sup>3</sup> /h]	Noise level IEC 60704-2-13 [dBA]
Speed 1	240	46
Speed 2	336	55

Speed 3	448	62
Intensive speed	603	69

## Performance / Energy Label



Annual Efficiency Consumption (AEChood)	58 kWh/a	Airbourne acoustical A-weighted sound Power Emission at minimum speed (SPEmin)	46 dBA
Energy efficiency class (EEC)	B	Airborne acoustical A-weighted sound Power Emission at maximum speed (SPEmax)	62 dBA
Fluid Dynamic Efficiency (FDE)	28	Airbourne acoustical A-weighted sound power emission at boost speed (SPEboost)	69 dBA
Fluid Dynamic Efficiency class (FDEC)	B	Power consumption in stand-by mode (Ps)	0.49 W
Lighting Efficiency (LE)	29 lux/W	Time increase factor (F)	1.00
Lighting Efficiency Class (LEC)	A	Measured air flow rate at best efficiency point (Qbep)	336 m <sup>3</sup> /h
Grease Filtering Efficiency (GFE)	66 %	Measured air pressure at best efficiency point (Pbep)	434 Pa
Grease Filtering Efficiency Class (GFEC)	D	Measured electric power input at best efficiency point (Wbep)	145 W
Air flow at mininum speed (Qmin)	240 m <sup>3</sup> /h	Nominal Power consumption of the light system (WL)	8 W
Air flow at maximum speed (Qmax)	448 m <sup>3</sup> /h	Average illumination of the light on the cooking surface (Emiddle)	218 lux
Air flow at boost speed (Qboost)	603 m <sup>3</sup> /h	Sound power level at highest setting (Lwa)	62 dBA

## Electrical Connection

Plug	Not present	Frequency (Hz)	50 Hz
Electrical connection rating	268 W	Power supply cable length	1500 mm
Voltage	220-240 V		

## Optional accessories

Charcoal filter	KITFC900 - KITFC999	Chimney extension	KITCMNKAT
-----------------	---------------------	-------------------	-----------

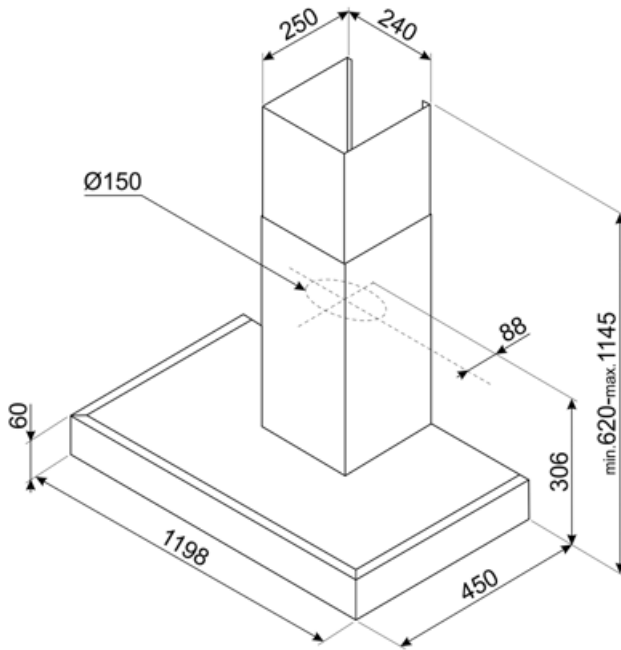

---

## Not included accessories

---



### KITFC900

Charcoal filter Kit 1 piece high performances washable



### KITFC999

Charcoal filter Kit 1 piece



### KITCMNKAT

Chimney extension dimension 241 \* 231 \* 810 T-shape hood KAT & KATE  
Stainless Steel

---

## Symbols glossary (TT)

---



**Filters:** Model has filters to help remove grease from the steam emanating from the pans during cooking.



**Warning light(s):** to advise when filters need changing.



**Lights:** All cooker hoods feature lights to illuminate the cooking area or add to the ambience of the kitchen.



**Intensive/turbo setting:** when extra fast extraction is required.

