

KAT900HXE

Product family	Hood
Hood Type	Decorative wall hood
Design	T flat
Extraction	Extraction
Material	Stainless steel
Type of steel	Brushed
EAN code	8017709201548
Hood width	90 cm



Aesthetics

Aesthetic Colour	Universale Stainless steel	Finishing Logo	Satin Silk screen
------------------	-------------------------------	----------------	----------------------

Controls

Control setting	Buttons
-----------------	---------

Technical Features



No. of lights	2	Anti-grease filters	Aluminium
Light type	LED	Filter replacement indicator	Yes
Light Power	2 W	Vent outlet	150 mm
Light color temperature scale (°K)	3500 °K	Minimum distance from GAS hob	650 mm
Free outlet maximum capacity	750 m³/h	Minimum distance from ELECTRIC hob	500 mm
Motor power	260 W	Non return valve	Yes
No. of filters	3		

	Extraction rate IEC 61591 [m³/h]	Noise level IEC 60704-2-13 [dBA]
Speed 1	240	46
Speed 2	336	55

Speed 3	448	62
Intensive speed	603	69

Performance / Energy Label



Annual Efficiency Consumption (AEChood)	56 kWh/a	Airbourne acoustical A-weighted sound Power Emission at minimum speed (SPEmin)	46 dBA
Energy efficiency class (EEC)	B	Airborne acoustical A-weighted sound Power Emission at maximum speed (SPEmax)	62 dBA
Fluid Dynamic Efficiency (FDE)	28	Airbourne acoustical A-weighted sound power emission at boost speed (SPEboost)	69 dBA
Fluid Dynamic Efficiency class (FDEC)	B	Power consumption in stand-by mode (Ps)	0,49 W
Lighting Efficiency (LE)	29 lux/W	Time increase factor (F)	1,00
Lighting Efficiency Class (LEC)	A	Measured air flow rate at best efficiency point (Qbep)	336 m ³ /h
Grease Filtering Efficiency (GFE)	66 %	Measured air pressure at best efficiency point (Pbep)	434 Pa
Grease Filtering Efficiency Class (GFEC)	D	Measured electric power input at best efficiency point (Wbep)	145 W
Air flow at minumum speed (Qmin)	240 m ³ /h	Nominal Power consumption of the light system (WL)	5 W
Air flow at maximum speed (Qmax)	448 m ³ /h	Average illumination of the light on the cooking surface (Emiddle)	145 lux
Air flow at boost speed (Qboost)	603 m ³ /h	Sound power level at highest setting (Lwa)	62 dBA

Electrical Connection

Plug	Not present	Frequency (Hz)	50 Hz
Electrical connection rating	265 W	Power supply cable length	1500 mm
Voltage	220-240 V		

Optional accessories

Charcoal filter	KITFC900 - KITFC999	Chimney extension	KITCMNKAT
-----------------	---------------------	-------------------	-----------

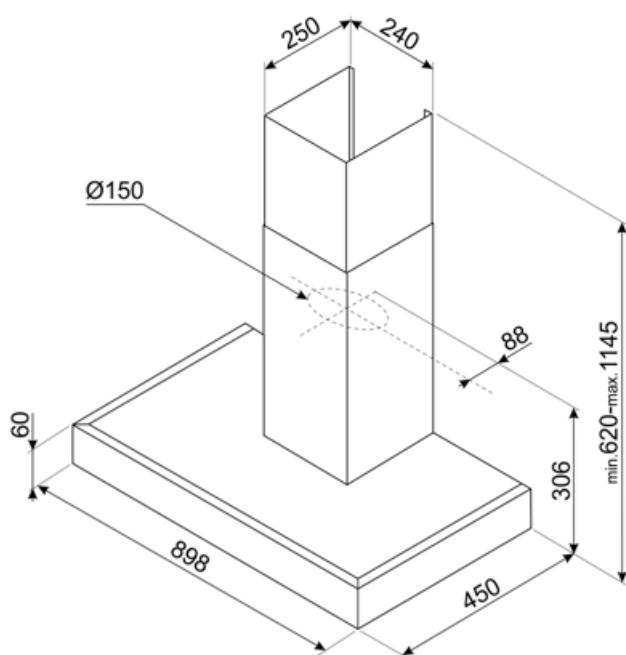

Not included accessories



KITCMNKAT

Chimney extension dimension 241 * 231
* 810 T-shape hood KAT & KATE
Stainless Steel



KITFC900

Charcoal filter Kit 1 piece high
performances washable



KITFC999

Charcoal filter Kit 1 piece

Symbols glossary (TT)



Filters: Model has filters to help remove grease from the steam emanating from the pans during cooking.



Warning light(s): to advise when filters need changing.



Lights: All cooker hoods feature lights to illuminate the cooking area or add to the ambience of the kitchen.



Intensive/turbo setting: when extra fast extraction is required.

