

KATE900CEX

Product family	Hood
Tipo de Exaustor	Decorative wall hood
Design	T flat
Extraction	Extraction
Electronic control	No
Perimeter extraction	No
Material	Stainless steel
Type of steel	Brushed
EAN code	8017709255060
Aesthetic	Universal
Colour	Stainless steel
Acabamento	Satin
Cor da serigrafia	Serigrafia em preto
Logotipo	Logotipo serigrafado



Controls

Control setting	Buttons
-----------------	---------

Program / Functions

No. of speeds	3
Intensive speed	No
24h air filter function	No
Other functions	No
Time-setting options	No
Other options	No
Ventilação automática	No

Technical Features



Hood without motor	No	No. of filters	3
Remote motor	No	Anti-grease filters	Aluminium
No. of lights	2	Charcoal filters included	Yes
Light type	LED	Filter replacement indicator	Yes
Light Power	2.5 W	Vent outlet	150 mm
Dimmer mode	No	Minimum distance from GAS hob	650 mm
Escala de temperatura de cor clara (°K)	3500 °K	Minimum distance from ELECTRIC hob	500 mm
Free outlet maximum capacity	612 m ³ /h	Non return valve	Yes
Motor power	175 W		

	Extraction rate IEC 61591 [m ³ /h]	Noise level IEC 60704-2-13 [dBA]
Speed 1	241	46
Speed 2	370	56
Speed 3	590	68

Accessories Included

Remote control	No	Tube reduction	No
Sliding door	No		

Performance / Energy Label



Consumo anual de energia (CAE exaustor)	77 kWh/a	Airbourne acoustical A-weighted sound Power Emission at minimum speed (SPEmin)	47 dBA
Energy efficiency class (EEC)	C	Airborne acoustical A-weighted sound Power Emission at maximum speed (SPEmax)	68 dBA
Fluid Dynamic Efficiency (FDE)	20,2	Time increase factor (F)	1,3
Fluid Dynamic Efficiency class (FDEC)	C	Measured air flow rate at best efficiency point (Qbep)	336 m ³ /h
Lighting Efficiency (LE)	76,1 lux/W	Measured air pressure at best efficiency point (Pbep)	334 Pa
Lighting Efficiency Class (LEC)	A	Measured electric power input at best efficiency point (Wbep)	155 W
Grease Filtering Efficiency (GFE)	76 %	Nominal Power consumption of the light system (WL)	5 W
Grease Filtering Efficiency Class (GFEC)	C	Average illumination of the light on the cooking surface (Emiddle)	381 lux
Air flow at minumum speed (Qmin)	240 m ³ /h	Sound power level at highest setting (Lwa)	68 dBA
Air flow at maximum speed (Qmax)	581 m ³ /h		

Electrical Connection

Plug	No	Frequency (Hz)	50-60 Hz
Electrical connection rating	180 W	Comprimento do cabo de alimentação	1500 mm
Voltage	220-240 V		

Optional accessories

Charcoal filter	No	Non return valve	No
Remote control	No	Kit with aesthetic components	No
Chimney extension	KITCMNKAT	Diffuser kit	No
Vent outlet	No		

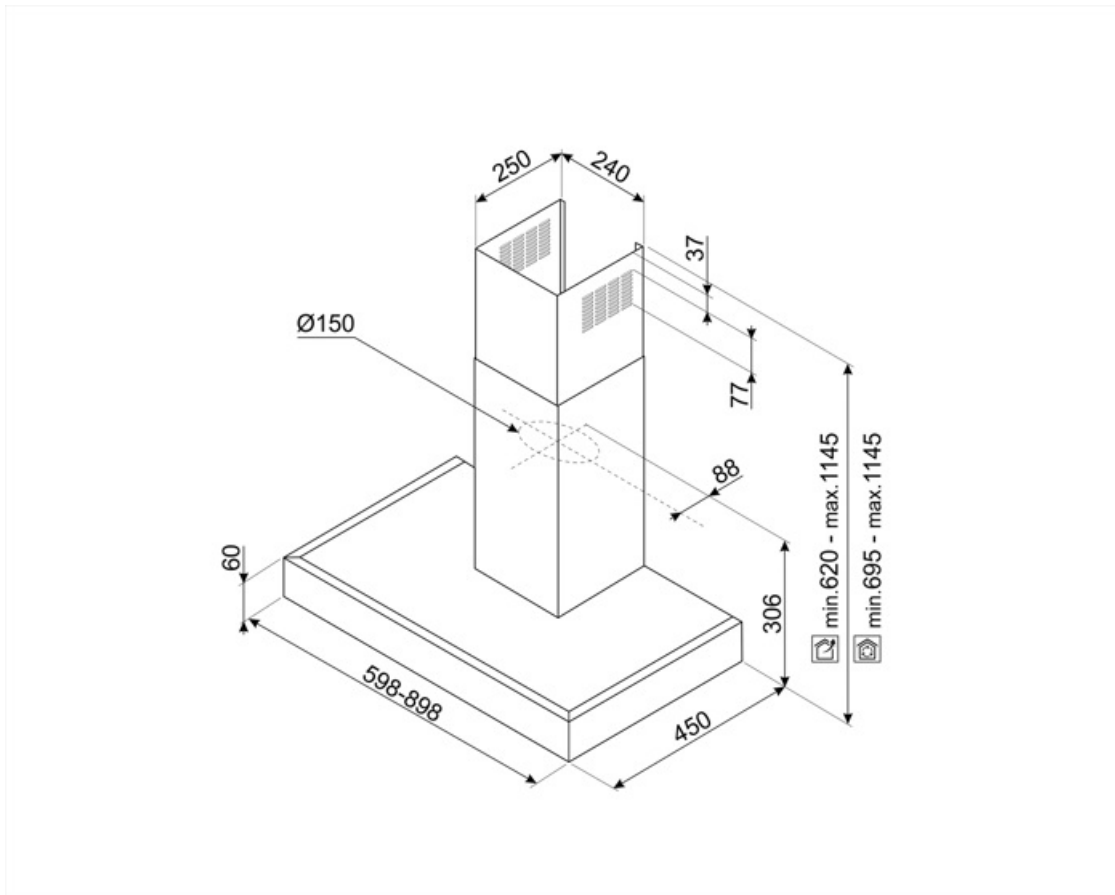

Compatible Accessories



KITCMNKAT

Dimensão de extensão da chaminé 241
* 231 * 810 Exaustor em T KAT & KATE
Aço Inoxidável

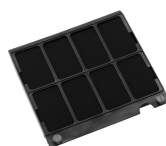

KITFC900

Kit filtro de carvão 1 peça de alto
desempenho lavável

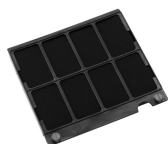

KITFC999

Kit filtro de carvão 1 peça

Symbols glossary



Filtros: O modelo tem filtros para ajudar a remover a graxa do vapor que emana das panelas durante o cozimento.



Filtros de carvão: Extrair através de filtros de carvão ou diretamente para o exterior diminui consideravelmente os fortes odores de cozimento.



Luzes: Todos os exaustores possuem luzes para iluminar a área de cozinhar ou adicionar ao ambiente da cozinha.



Luz(s) de aviso: para avisar quando os filtros precisam ser trocados.