

KBT1200XE

| | |
|--------------------|----------------------|
| Product family | Hood |
| Hood Type | Decorative wall hood |
| Design | T flat |
| Extraction | Extraction |
| Electronic control | Yes |
| Material | Stainless steel |
| Type of steel | Brushed |
| EAN code | 8017709286637 |
| Hood width | 120 cm |





Aesthetics

| | | | |
|------------------|----------------------------|----------------|-------------------|
| Aesthetic Colour | Universale Stainless steel | Finishing Logo | Satin Silk screen |
|------------------|----------------------------|----------------|-------------------|



Controls

| | |
|-----------------|--------------------|
| Control setting | Electronic buttons |
|-----------------|--------------------|

Programs / Functions main oven

| | |
|-------------------------|---|
| No. of speeds | 3 |
| Intensive speed |  |
| 24h air filter function |  |
| Time-setting options |  |

Technical Features

| | | | |
|--|---------|-------------------------------|-----------|
|    | | | |
| No. of lights | 2 | Anti-grease filters | Aluminium |
| Light type | LED | Filter replacement indicator | Yes |
| Light Power | 1.3 W | Vent outlet | 150 mm |
| Light color temperature scale (°K) | 3000 °K | Minimum distance from GAS hob | 650 mm |

| | | | |
|-------------------------------------|-----------------------|---|--------|
| Free outlet maximum capacity | 610 m ³ /h | Minimum distance from ELECTRIC hob | 650 mm |
| Motor power | 230 W | Non return valve | Yes |
| No. of filters | 4 | | |

| | Extraction rate IEC 61591 [m³/h] | Noise level IEC 60704-2-13 [dBA] |
|-----------------|--|---|
| Speed 1 | 251 | 48 |
| Speed 2 | 345 | 56 |
| Speed 3 | 454 | 62 |
| Intensive speed | 690 | 72 |

Accessories Included

| | |
|-----------------------|-----|
| Tube reduction | Yes |
|-----------------------|-----|

Performance / Energy Label



| | | | |
|--|-----------------------|---|-----------------------|
| Annual Efficiency Consumption (AEChood) | 55 kWh/a | Airborne acoustical A-weighted sound Power Emission at maximum speed (SPEmax) | 61 dBA |
| Energy efficiency class (EEC) | A | Airbourne acoustical A-weighted sound power emission at boost speed (SPEboost) | 71 dBA |
| Fluid Dynamic Efficiency (FDE) | 30,2 | Power consumption in stand-by mode (Ps) | 0,23 W |
| Fluid Dynamic Efficiency class (FDEC) | A | Time increase factor (F) | 0,9 |
| Lighting Efficiency (LE) | 58,8 lux/W | Energy Efficiency Index | 52,1 |
| Lighting Efficiency Class (LEC) | A | Measured air flow rate at best efficiency point (Qbep) | 387 m ³ /h |
| Grease Filtering Efficiency (GFE) | 79,6 % | Measured air pressure at best efficiency point (Pbep) | 452 Pa |
| Grease Filtering Efficiency Class (GFEC) | C | Measured electric power input at best efficiency point (Wbep) | 161 W |
| Air flow at minumum speed (Qmin) | 251 m ³ /h | Nominal Power consumption of the light system (WL) | 3 W |
| Air flow at maximum speed (Qmax) | 454 m ³ /h | Average illumination of the light on the cooking surface (Emiddle) | 153 lux |
| Air flow at boost speed (Qboost) | 690 m ³ /h | Sound power level at highest setting (Lwa) | 72 dBA |
| Airbourne acouistical A-weighted sound Power Emission at minimum speed (SPEmin) | 47 dBA | | |

Electrical Connection

| | | | |
|------------------------------|-------------|---------------------------|----------|
| Plug | Not present | Frequency (Hz) | 50-60 Hz |
| Electrical connection rating | 230 W | Power supply cable length | 1500 mm |
| Voltage | 220-240 V | | |

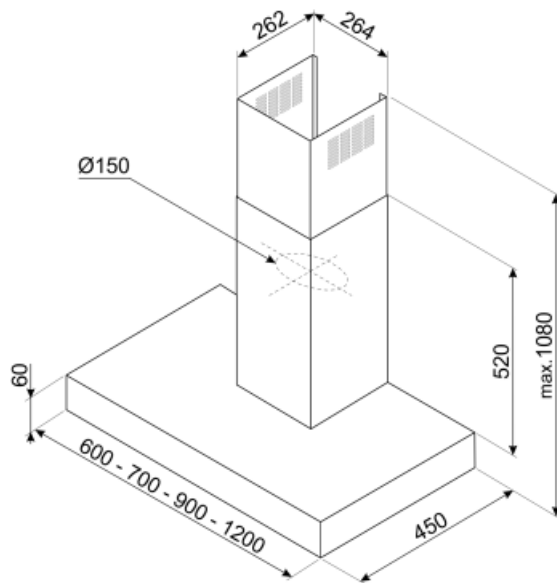

Not included accessories



KITFCKBT

1 pcs di filtro a carboni attivi per i modelli di cappe KBT* / KBCT*

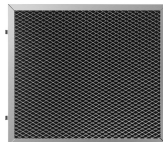

KITFCKBTR







1 pcs of Charcoal filter Regenerable* suitable for all the KBT/KBCT models.
* It can be washed in the dishwasher up to 12 times and dry in the oven at max 90° for 60 min. dimension 237,5(H)x245x10 mm



KITCEKBT

Chimney extension, dimensions 261,5 * 260 * 830 mm suitable for T-shape hood KBT* & KBCT*, max hight 1380 mm Stainless Steel

Symbols glossary (TT)

- | | | | |
|--|---|---|--|
|  | 24h: When selected this function refreshes the air for c. 10 minutes every hour over a 24 hour period, at minimum speed and an imperceptible noise level. |  | |
|  | Filters: Model has filters to help remove grease from the steam emanating from the pans during cooking. |  | Switch off automatically: A special setting, to run after the end of cooking for a pre-set time and then switch off automatically. |
|  | Warning light(s): to advise when filters need changing. |  | Lights: All cooker hoods feature lights to illuminate the cooking area or add to the ambience of the kitchen. |
|  | Intensive/turbo setting: when extra fast extraction is required. | | |