

KBT900NE

Product family	Hood
Hood Type	Decorative wall hood
Design	T flat
Extraction	Extraction
Electronic control	Yes
Material	Painted material
Type of steel	Brushed
EAN code	8017709299811
Hood width	90 cm





Aesthetics

Aesthetic Colour	Universale Matt Black	Finishing Logo	Matt Silk screen
------------------	-----------------------	----------------	------------------



Controls

Control setting	Electronic buttons
-----------------	--------------------

Programme / Functions

No. of speeds	3
Intensive speed	
24h air filter function	
Time-setting options	

Technical Features

  			
No. of lights	2	Anti-grease filters	Aluminium
Light type	LED	Filter replacement indicator	Yes
Light Power	1.3 W	Vent outlet	150 mm
Free outlet maximum capacity	730 m ³ /h	Minimum distance from GAS hob	650 mm
Motor power	230 W		

No. of filters	3	Minimum distance from ELECTRIC hob	500 mm
		Non return valve	Yes

	Extraction rate IEC 61591 [m ³ /h]	Noise level IEC 60704-2-13 [dBA]
Speed 1	265	47
Speed 2	360	55
Speed 3	480	62
Intensive speed	713	72

Accessories Included

Tube reduction	Yes
----------------	-----

Performance / Energy Label



Annual Efficiency Consumption (AEC _{hood})	54 kWh/a	Airborne acoustical A-weighted sound Power Emission at maximum speed (SPE _{max})	62 dBA
Energy efficiency class (EEC)	A	Airbourne acoustical A-weighted sound power emission at boost speed (SPE _{boost})	71 dBA
Fluid Dynamic Efficiency (FDE)	31.2	Power consumption in stand-by mode (Ps)	0.22 W
Fluid Dynamic Efficiency class (FDEC)	A	Time increase factor (F)	0.9
Lighting Efficiency (LE)	60.0 lux/W	Energy Efficiency Index	52.0
Lighting Efficiency Class (LEC)	A	Measured air flow rate at best efficiency point (Q _{bep})	395 m ³ /h
Grease Filtering Efficiency (GFE)	76.5 %	Measured air pressure at best efficiency point (P _{bep})	451 Pa
Grease Filtering Efficiency Class (GFEC)	C	Measured electric power input at best efficiency point (W _{bep})	159 W
Air flow at minimum speed (Q _{min})	265 m ³ /h	Nominal Power consumption of the light system (WL)	3 W
Air flow at maximum speed (Q _{max})	480 m ³ /h	Average illumination of the light on the cooking surface (E _{middle})	156 lux
Air flow at boost speed (Q _{boost})	713 m ³ /h	Sound power level at highest setting (L _{wa})	62 dBA
Airbourne acoustical A-weighted sound Power Emission at minimum speed (SPE _{min})	46 dBA		

Electrical Connection

Plug	Not present	Frequency (Hz)	50-60 Hz
Electrical connection rating	230 W	Power supply cable length	1500 mm
Voltage	220-240 V		

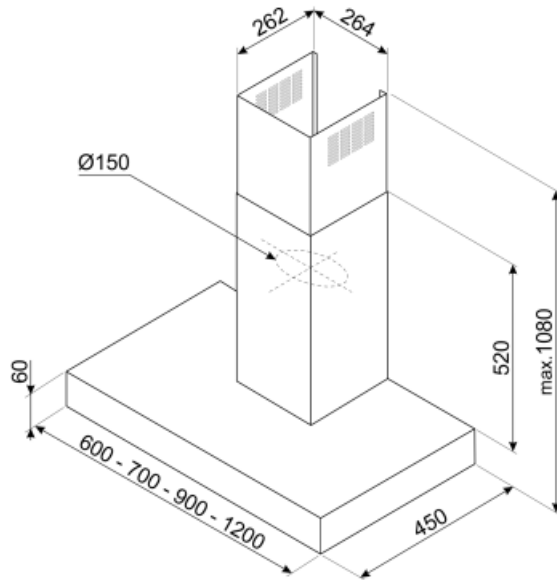

Not included accessories

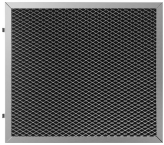

KITFCKBT

1 pcs di filtro a carboni attivi per i modelli di cappe KBT* / KBCT*

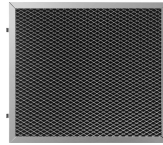







KITFCKBTR

1 pcs of Charcoal filter Regenerable* suitable for all the KBT/KBCT models.
* It can be washed in the dishwasher up to 12 times and dry in the oven at max 90° for 60 min. dimension 237,5(H)x245x10 mm



KITCEKBTMB

Symbols glossary (TT)

- | | | | |
|--|---|---|--|
|  | 24h: When selected this function refreshes the air for c. 10 minutes every hour over a 24 hour period, at minimum speed and an imperceptible noise level. |  | |
|  | Filters: Model has filters to help remove grease from the steam emanating from the pans during cooking. |  | Switch off automatically: A special setting, to run after the end of cooking for a pre-set time and then switch off automatically. |
|  | Warning light(s): to advise when filters need changing. |  | Lights: All cooker hoods feature lights to illuminate the cooking area or add to the ambience of the kitchen. |
|  | Intensive/turbo setting: when extra fast extraction is required. | | |