

KCI19AOE

Product family	Hood
Tipo de Exaustor	Decorative island hood
Design	Rounded
Extraction	Extraction
Electronic control	No
Perimeter extraction	No
Material	Heat-moulded
EAN code	8017709212506
Aesthetic	Cortina
Colour	Anthracite
Components finishing	Antique brass
Logotipo	Logotipo aplicado





Controls

Control setting	Control knobs	Controls colour	Anthracite
No. of controls	2	Display	No
Control knobs	Cortina		

Program / Functions

No. of speeds	3
Intensive speed	
24h air filter function	No
Other functions	No
Time-setting options	No
Other options	No
Ventilação automática	No

Technical Features

			
Hood without motor	No	No. of filters	3
Remote motor	No	Anti-grease filters	Aluminium
No. of lights	4	Charcoal filters included	No
Light type	LED	Filter replacement indicator	No
Light Power	1 W	Vent outlet	150 mm
Dimmer mode	No	Minimum distance from GAS hob	750 mm
Escala de temperatura de cor clara (°K)	3000 °K		

Free outlet maximum capacity	820 m ³ /h	Minimum distance from ELECTRIC hob	650 mm
Motor power	275 W	Non return valve	Yes

	Extraction rate IEC 61591 [m ³ /h]	Noise level IEC 60704-2-13 [dBA]
Speed 1	321	47
Speed 2	385	59
Speed 3	549	61
Intensive speed	796	70

Accessories Included

Remote control	No	Tube reduction	Yes
Sliding door	No		

Performance / Energy Label



Consumo anual de energía (CAE exaustor)	59 kWh/a	Airbourne acoustical A-weighted sound Power Emission at minimum speed (SPEmin)	47 dBA
Energy efficiency class (EEC)	A	Airborne acoustical A-weighted sound Power Emission at maximum speed (SPEmax)	61 dBA
Fluid Dynamic Efficiency (FDE)	25,9	Airbourne acoustical A-weighted sound power emission at boost speed (SPEboost)	70 dBA
Fluid Dynamic Efficiency class (FDEC)	A	Time increase factor (F)	0,9
Lighting Efficiency (LE)	68,6 lux/W	Energy Efficiency Index	53,1
Lighting Efficiency Class (LEC)	A	Measured air flow rate at best efficiency point (Qbep)	426 m ³ /h
Grease Filtering Efficiency (GFE)	78 %	Measured air pressure at best efficiency point (Pbep)	453 Pa
Grease Filtering Efficiency Class (GFEC)	C	Measured electric power input at best efficiency point (Wbep)	170 W
Air flow at minumum speed (Qmin)	321 m ³ /h	Nominal Power consumption of the light system (WL)	4 W
Air flow at maximum speed (Qmax)	549 m ³ /h	Average illumination of the light on the cooking surface (Emiddle)	302 lux
Air flow at boost speed (Qboost)	796 m ³ /h	Sound power level at highest setting (Lwa)	61 dBA

Electrical Connection

Plug	No	Frequency (Hz)	50-60 Hz
Electrical connection rating	279 W	Comprimento do cabo de alimentação	1000 mm
Voltage	220-240 V		

Also available

Outras cores disponíveis	Crema	Códigos das outras cores disponíveis	KCI19POE
--------------------------	-------	--------------------------------------	----------

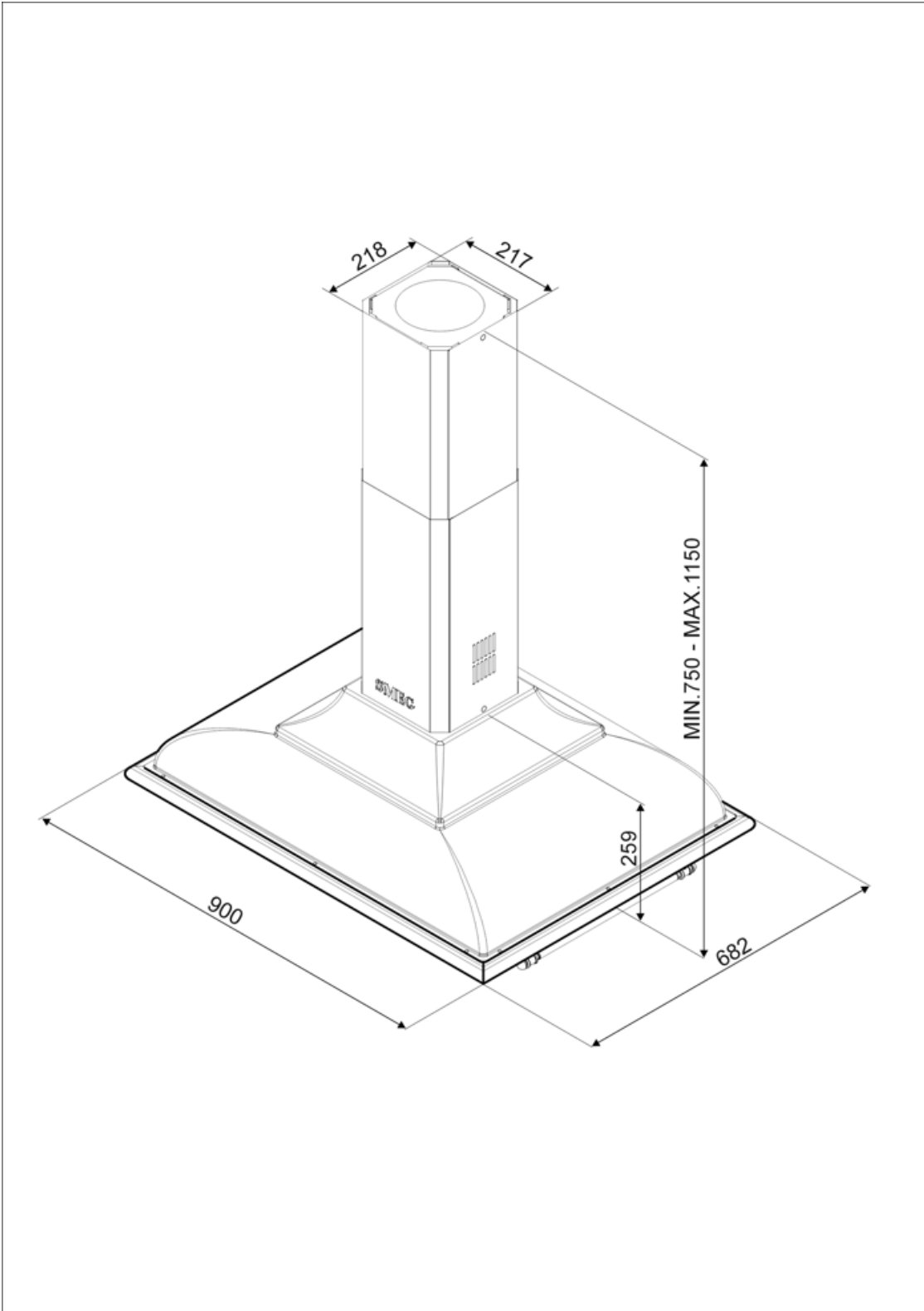

Compatible Accessories

FLT6

Filtros de carvão redondos (kit 2 peças)



KITLOGOCR

LOGOTIPO DO KIT ACABAMENTO
CROMADO



KITLOGOAS

KIT LOGO ACABAMENTO PRATEADO
ANTIGO



Symbols glossary



Filtros: O modelo tem filtros para ajudar a remover a graxa do vapor que emana das panelas durante o cozimento.



Luzes: Todos os exaustores possuem luzes para iluminar a área de cozinhar ou adicionar ao ambiente da cozinha.



R: Desempenho de secagem do produto, medido de A++ a D/G, dependendo da família de produtos



Configuração intensiva/turbo: quando a extração extra rápida é necessária.