

KD91XE3

Product family	Hood
Tipo de Exaustor	Decorative wall hood
Design	Chimney
Extraction	Extraction
Electronic control	No
Perimeter extraction	No
Material	Stainless steel
Type of steel	Brushed
EAN code	8017709345976
Aesthetic	Universal
Colour	Stainless steel
Acabamento	Satin
Logotipo	Logotipo embutido



Controls

Control setting Buttons

Program / Functions

No. of speeds	3
Intensive speed	No
24h air filter function	No
Other functions	No
Time-setting options	No
Other options	No
Ventilação automática	No

Technical Features



Hood without motor	No	No. of filters	3
Remote motor	No	Anti-grease filters	Aluminium
No. of lights	2	Charcoal filters included	No
Light type	LED	Filter replacement indicator	No
Light Power	4 W	Vent outlet	150 mm
Dimmer mode	No	Minimum distance from GAS hob	650 mm
Escala de temperatura de cor clara (°K)	4000 °K	Minimum distance from ELECTRIC hob	500 mm
Free outlet maximum capacity	620 m ³ /h	Non return valve	No
Motor power	160 W		

	Extraction rate IEC 61591 [m³/h]	Noise level IEC 60704-2-13 [dBA]
Speed 1	260	45
Speed 2	390	54
Speed 3	600	63

Accessories Included

Remote control	No	Tube reduction	Yes
Sliding door	No		

Performance / Energy Label



Consumo anual de energía (CAE exaustor)	79 kWh/a	Airbourne acoustical A-weighted sound Power Emission at minimum speed (SPEmin)	45 dBA
Energy efficiency class (EEC)	C	Airborne acoustical A-weighted sound Power Emission at maximum speed (SPEmax)	63 dBA
Fluid Dynamic Efficiency (FDE)	18,20	Time increase factor (F)	1,3
Fluid Dynamic Efficiency class (FDEC)	C	Energy Efficiency Index	75,6
Lighting Efficiency (LE)	17 lux/W	Measured air flow rate at best efficiency point (Qbep)	338 m³/h
Lighting Efficiency Class (LEC)	C	Measured air pressure at best efficiency point (Pbep)	300 Pa
Grease Filtering Efficiency (GFE)	75,1 %	Measured electric power input at best efficiency point (Wbep)	155 W
Grease Filtering Efficiency Class (GFEC)	C	Nominal Power consumption of the light system (WL)	8 W
Air flow at minimum speed (Qmin)	260 m³/h	Average illumination of the light on the cooking surface (Emiddle)	133 lux
Air flow at maximum speed (Qmax)	600 m³/h	Sound power level at highest setting (Lwa)	63 dBA

Electrical Connection

Plug	No	Frequency (Hz)	50-60 Hz
Electrical connection rating	168 W	Comprimento do cabo de alimentação	1500 mm
Voltage	220-240 V		

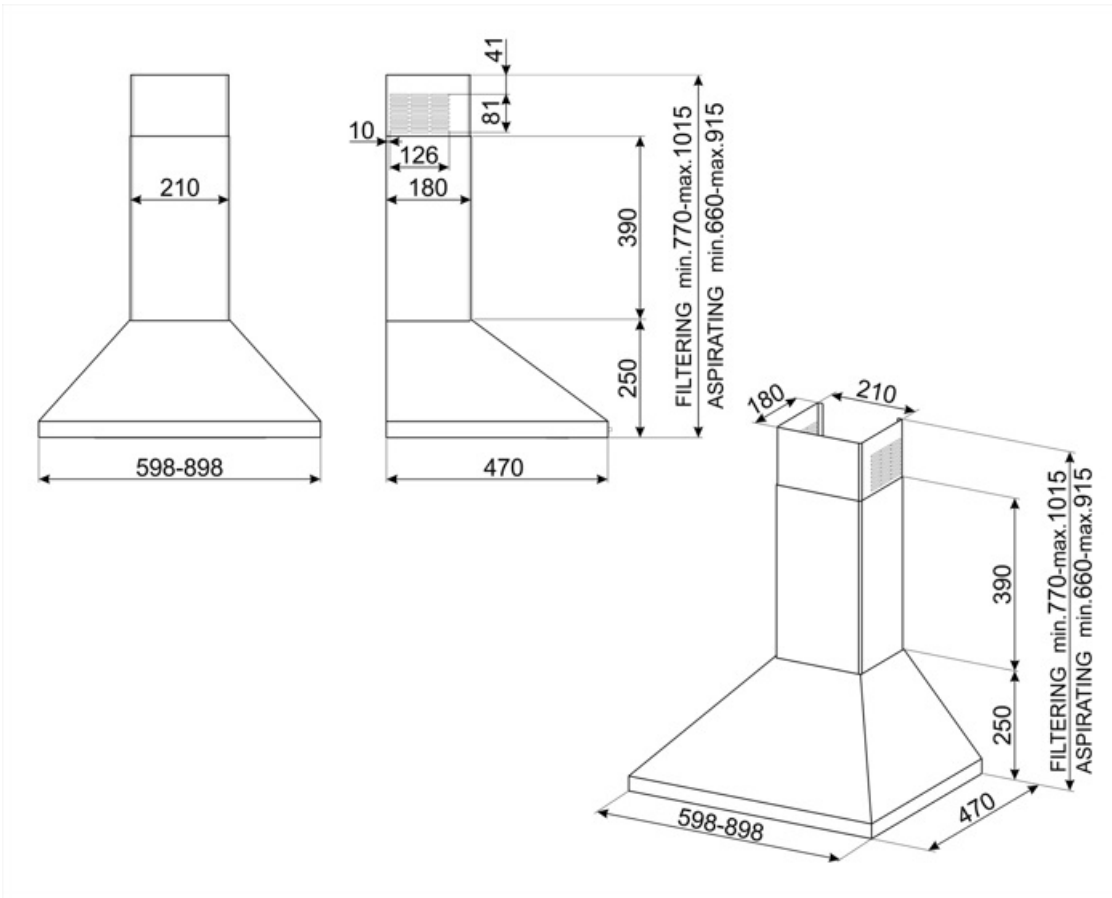

Compatible Accessories

KITFC152

Filtro de carvão Redondo Kit 2 peças



Symbols glossary



Filtros: O modelo tem filtros para ajudar a remover a graxa do vapor que emana das panelas durante o cozimento.



Luzes: Todos os exaustores possuem luzes para iluminar a área de cozinhar ou adicionar ao ambiente da cozinha.