

KFAB75UJ



Product family	Hood
Tipo de Exaustor	Decorative wall hood
Design	Angled
Extraction	Recirculation
Electronic control	Yes
Perimeter extraction	No
Material	Painted material
Type of steel	Brushed
EAN code	8017709251475
Aesthetic	Estilo anos '50
Colour	Decorated / Special
Acabamento	Brilhante
Decoration / Special colour	Union Jack
Logotipo	Logotipo aplicado



Controls

Control setting	Electronic buttons	Led color	White
-----------------	--------------------	-----------	-------

Program / Functions

No. of speeds	3
Intensive speed	
24h air filter function	No
Other functions	No
Time-setting options	
Other options	No
Ventilação automática	No

Technical Features



Hood without motor	No	No. of filters	3
Remote motor	No	Anti-grease filters	Stainless steel
No. of lights	2	Charcoal filters included	Yes
Light type	LED	Filter replacement indicator	Yes
Light Power	1 W	Vent outlet	150 mm
Dimmer mode	No	Minimum distance from GAS hob	650 mm
Escala de temperatura de cor clara (°K)	4000 °K	Minimum distance from ELECTRIC hob	650 mm
Free outlet maximum capacity	820 m³/h		

Motor power 280 W Non return valve Yes

	Extraction rate IEC 61591 [m ³ /h]	Noise level IEC 60704-2-13 [dBA]
Speed 1	333	50
Speed 2	477	59
Speed 3	649	67
Intensive speed	797	72

Accessories Included

Remote control Yes Tube reduction No
Sliding door Yes

Performance / Energy Label



Consumo anual de energía (CAE exaustor)	36 kWh/a	Airborne acoustical A-weighted sound Power Emission at maximum speed (SPEmax)	67 dBA
Energy efficiency class (EEC)	A+	Airbourne acoustical A-weighted sound power emission at boost speed (SPEboost)	72 dBA
Fluid Dynamic Efficiency (FDE)	36.6	Power consumption in stand-by mode (Ps)	0.49 W
Fluid Dynamic Efficiency class (FDEC)	A	Time increase factor (F)	0.7
Lighting Efficiency (LE)	68.2 lux/W	Energy Efficiency Index	39.7
Lighting Efficiency Class (LEC)	A	Measured air flow rate at best efficiency point (Qbep)	421 m ³ /h
Grease Filtering Efficiency (GFE)	61.1 %	Measured air pressure at best efficiency point (Pbep)	422 Pa
Grease Filtering Efficiency Class (GFEC)	E	Measured electric power input at best efficiency point (Wbep)	135 W
Air flow at minumum speed (Qmin)	333 m ³ /h	Nominal Power consumption of the light system (WL)	2 W
Air flow at maximum speed (Qmax)	649 m ³ /h	Average illumination of the light on the cooking surface (Emiddle)	150 lux
Air flow at boost speed (Qboost)	797 m ³ /h	Sound power level at highest setting (Lwa)	67 dBA
Airbourne acoustical A-weighted sound Power Emission at minimum speed (SPEmin)	50 dBA		

Electrical Connection

Plug No Voltage 220-240 V

Battery type	Alkaline-Manganese Dioxide (Zn/MnO ₂)	Frequency (Hz)	50-60 Hz
Electrical connection rating	282 W	Comprimento do cabo de alimentação	1500 mm
Current	1 A		

Also available

Outras cores disponíveis Branca, Preta, Creme, Encarnada

Códigos das outras cores disponíveis

KFAB75WH-KFAB75BL-
KFAB75CR-KFAB75RD

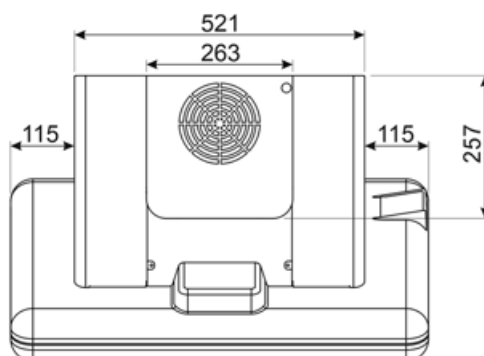
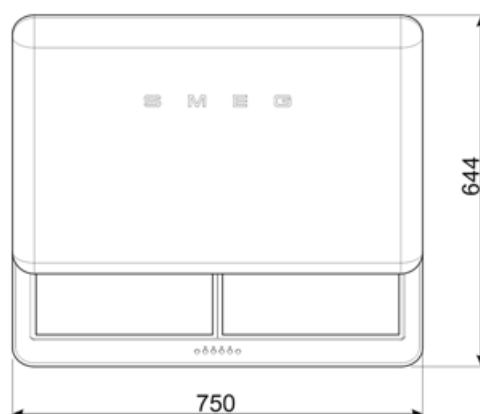
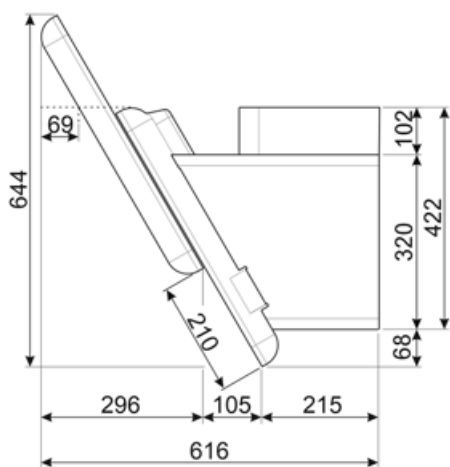

Compatible Accessories

FLTSI

Kit de filtros de carvão 2 peças

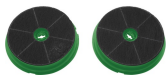

KITCMNFABUJ

Par de chaminés (2 peças) dimensões
550 mín 1035 máx (263 * 257 mm)
KFAB75UJ Exaustor Union JACK
Chaminés AZÚIS-ESCURO



Symbols glossary



Filtros: O modelo tem filtros para ajudar a remover a graxa do vapor que emana das panelas durante o cozimento.



Filtros de carvão: Extrair através de filtros de carvão ou diretamente para o exterior diminui consideravelmente os fortes odores de cozimento.



Luz(s) de aviso: para avisar quando os filtros precisam ser trocados.



Configuração intensiva/turbo: quando a extração extra rápida é necessária.



Desligar automaticamente: Uma configuração especial, para ser executada após o final do cozimento por um tempo pré-definido e, em seguida, desligar automaticamente.



A+: A classe de eficiência energética A+ ajuda a economizar até 10% de energia em comparação com a classe A. O desempenho máximo com consumo mínimo é garantido.



Luzes: Todos os exaustores possuem luzes para iluminar a área de cozinhar ou adicionar ao ambiente da cozinha.