

# KI905NXE2



Product family	Hood
Hood Type	Decorative island hood
Design	T flat
Extraction	Extraction
Electronic control	Yes
Material	Stainless steel
Type of steel	Brushed
EAN code	8017709253882
Hood width	90 cm



## Aesthetics

Aesthetic	Linea	Finishing	Satin
Colour	Black	Logo	Embossed

## Controls

			
Control setting	Touch control	Display	Yes
Led color	Ice		

## Programme / Functions

No. of speeds	3
Intensive speed	

## Technical Features

			
No. of lights	4	No. of filters	3
Light type	LED	Anti-grease filters	Aluminium
Light Power	1 W	Vent outlet	150 mm
Light color temperature scale (°K)	4000 °K	Minimum distance from GAS hob	650 mm
Free outlet maximum capacity	820 m <sup>3</sup> /h	Minimum distance from ELECTRIC hob	650 mm

Motor power 275 W Non return valve Yes

	Extraction rate IEC 61591 [m <sup>3</sup> /h]	Noise level IEC 60704-2-13 [dB(A)]
Speed 1	266	49
Speed 2	385	59
Speed 3	469	61
Intensive speed	703	70

## Performance / Energy Label

<b>B</b>	Annual Efficiency Consumption (AEC <sub>hood</sub> )	68 kWh/a	Airbourne acoustical A-weighted sound Power Emission at minimum speed (SPE <sub>min</sub> )	49 dB(A)
	Energy efficiency class (EEC)	B	Airborne acoustical A-weighted sound Power Emission at maximum speed (SPE <sub>max</sub> )	61 dB(A)
	Fluid Dynamic Efficiency (FDE)	27,9	Airbourne acoustical A-weighted sound power emission at boost speed (SPE <sub>boost</sub> )	70 dB(A)
	Fluid Dynamic Efficiency class (FDEC)	B	Power Consumption in Off mode (P <sub>o</sub> )	0,49 W
	Lighting Efficiency (LE)	79,8 lux/W	Time increase factor (F)	1,00
	Lighting Efficiency Class (LEC)	A	Measured air flow rate at best efficiency point (Q <sub>bep</sub> )	399 m <sup>3</sup> /h
	Grease Filtering Efficiency (GFE)	84,3 %	Measured air pressure at best efficiency point (P <sub>bep</sub> )	445 Pa
	Grease Filtering Efficiency Class (GFEC)	C	Measured electric power input at best efficiency point (W <sub>bep</sub> )	176 W
	Air flow at minumum speed (Q <sub>min</sub> )	266 m <sup>3</sup> /h	Nominal Power consumption of the light system (WL)	4 W
	Air flow at maximum speed (Q <sub>max</sub> )	469 m <sup>3</sup> /h	Average illumination of the light on the cooking surface (E <sub>middle</sub> )	351 lux
	Air flow at boost speed (Q <sub>boost</sub> )	703 m <sup>3</sup> /h	Sound power level at highest setting (L <sub>wa</sub> )	61 dB(A)

## Electrical Connection

Electrical connection rating	279 W	Frequency (Hz)	50-60 Hz
Voltage	220-240 V	Power supply cable length	1500 mm

## Optional accessories

---

Charcoal filter

FLT6

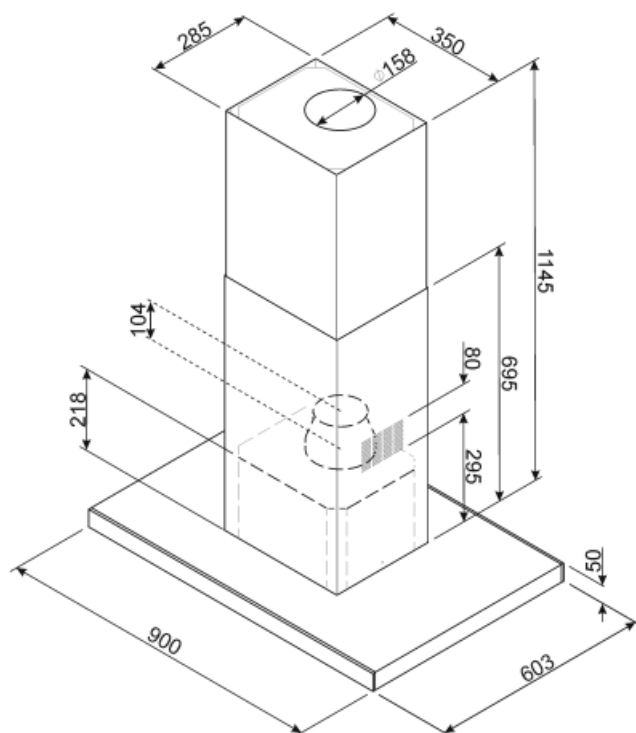

## Not included accessories

---



### FLT6

Round Charcoal filters (kit 2 pieces)









### KITALLFC

Universal Charcoal filter Stainless Steel AISI 304 The filter can be washed in dishwasher 50 °C (water and suitable detergent) and to dry it put in the oven 180°C 25 minutes

---

## Symbols glossary (TT)

---

- |  |  |   |  |
|--|--|---|--|
|  | <b>Filters:</b> Model has filters to help remove grease from the steam emanating from the pans during cooking.   |  | <b>LED display:</b> to show programmes, functions and options selected and the time to the end of the cycle.         |
|  | <b>B:</b> Product energy rating, measured from A+++ to D / G depending on the product family.                    |  | <b>Lights:</b> All cooker hoods feature lights to illuminate the cooking area or add to the ambience of the kitchen. |
|  | <b>Touch controls:</b> Easy to use touch controls allow the appliance to be programmed at the touch of a button. |  | <b>Intensive/turbo setting:</b> when extra fast extraction is required.  |