

# KIR37XE

Product family	Hood
Hood Type	Decorative island hood
Design	Cylindric
Extraction	Extraction
Electronic control	Yes
Material	Stainless steel
Type of steel	Brushed
EAN code	8017709203214
Aesthetic	Universale
Colour	Stainless steel
Finishing	Satin
Serigraphy colour	Black
Logo	Embossed



## Controls

Control setting	Electronic buttons	Led color	White
-----------------	--------------------	-----------	-------

## Programs / Functions

No. of speeds	3
Intensive speed	

## Technical Features



No. of lights	2	Anti-grease filters	Aluminium
Light type	LED	Filter replacement indicator	Yes
Light Power	1 W	Vent outlet	150 mm
Dimmer mode	Yes	Minimum distance from GAS hob	550 mm
Free outlet maximum capacity	800 m <sup>3</sup> /h	Minimum distance from ELECTRIC hob	550 mm
Motor power	270 W	Non return valve	Yes
No. of filters	1		

	Extraction rate IEC 61591 [m <sup>3</sup> /h]	Noise level IEC 60704-2-13 [dBA]
Speed 1	280	52
Speed 2	400	61

Speed 3	560	65
Intensive speed	660	68

## Accessories Included

Tube reduction Yes

## Performance / Energy Label



Annual Efficiency Consumption (AEChood)	69 kWh/a	Airborne acoustical A-weighted sound Power Emission at maximum speed (SPEmax)	65 dBA
Energy efficiency class (EEC)	B	Airbourne acoustical A-weighted sound power emission at boost speed (SPEboost)	68 dBA
Fluid Dynamic Efficiency (FDE)	24.6	Power Consumption in Off mode (Po)	0.49 W
Fluid Dynamic Efficiency class (FDEC)	B	Time increase factor (F)	1.1
Lighting Efficiency (LE)	118 lux/W	Energy Efficiency Index	51.7
Lighting Efficiency Class (LEC)	A	Measured air flow rate at best efficiency point (Qbep)	333 m <sup>3</sup> /h
Grease Filtering Efficiency (GFE)	85.3 %	Measured air pressure at best efficiency point (Pbep)	447 Pa
Grease Filtering Efficiency Class (GFEC)	B	Measured electric power input at best efficiency point (Wbep)	168 W
Air flow at minimum speed (Qmin)	280 m <sup>3</sup> /h	Nominal Power consumption of the light system (WL)	2 W
Air flow at maximum speed (Qmax)	560 m <sup>3</sup> /h	Average illumination of the light on the cooking surface (Emiddle)	260 lux
Air flow at boost speed (Qboost)	660 m <sup>3</sup> /h	Sound power level at highest setting (Lwa)	65 dBA
Airbourne acoustical A-weighted sound Power Emission at minimum speed (SPEmin)	52 dBA		

## Electrical Connection

Plug	Not present	Frequency (Hz)	50-60 Hz
Electrical connection rating	272 W	Power supply cable length	1500 mm
Voltage	220-240 V		

## Optional accessories

Charcoal filter

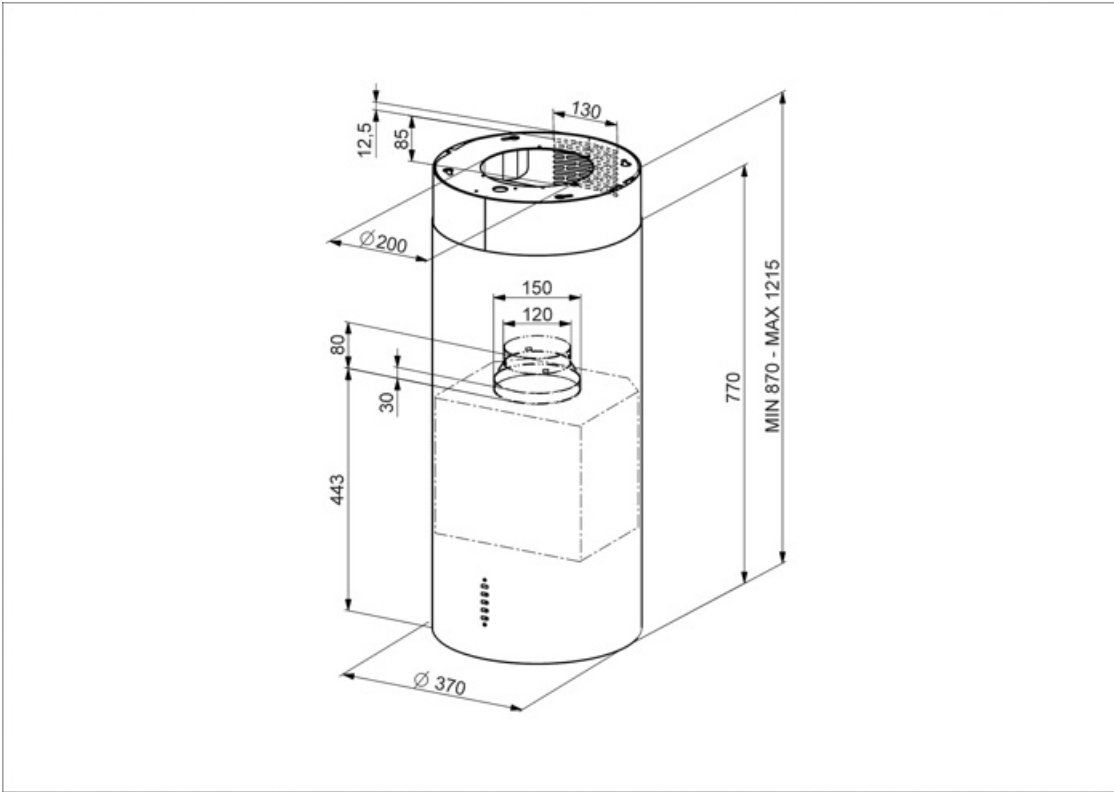

---

## Compatible Accessories

---



**KITFC161**

Charcoal filters Kit 1 pieces









**KITVENT150**

Imbocco motore 150 mm con valvola di non ritorno

---

## Symbols glossary

---

- |  |   |   |  |
|--|---|---|--|
|  | Filters: Model has filters to help remove grease from the steam emanating from the pans during cooking.       |  | Warning light(s): to advise when filters need changing.          |
|  | Lights: All cooker hoods feature lights to illuminate the cooking area or add to the ambience of the kitchen. |  | Intensive/turbo setting: when extra fast extraction is required. |
|  | Dimmering Lights  |  |  |