

KS110BLE

Product family	Hood
Hood Type	Chimney Cooker Hoods
Design	T flat
Extraction	Ducted out or re-circulation possible
Electronic control	Yes
Material	Painted material
Type of steel	Brushed
EAN code	8017709201845
Hood width	110 cm



Aesthetics

Aesthetics	Universal	Logo	Embossed
Colour	Black		

Controls

Control setting	Electronic buttons
-----------------	--------------------

Programs / Functions

No. of speeds	3
Intensive speed	
Time-setting options	

Technical Features

				
No. of lights	2	Anti-grease filters	Aluminium	
Light type	LED	Filter replacement indicator	Yes	
Light power	1 W	Vent outlet	150 mm	
Light colour	4000 °K	Minimum distance from GAS hob	750 mm	
temperature scale (°K)		Minimum distance from ELECTRIC hob	650 mm	
Free outlet maximum capacity	800 m ³ /h			
Motor power	275 W			

No. of filters 3 Non return valve Yes

	Extraction rate IEC 61591 [m³/h]	Noise level IEC 60704-2-13 [dBA]
Speed 1	295	51
Speed 2	395	58
Speed 3	513	64
Intensive speed	702	72

Performance / Energy Label



Annual Efficiency Consumption (AEChood)	62 KWh/year	Airborne acoustical A-weighted sound Power Emission at maximum speed (SPEmax)	64 dBA
Energy efficiency class (EEC)	B	Airbourne acoustical A-weighted sound power emission at boost speed (SPEboost)	72 dBA
Fluid Dynamic Efficiency (FDE)	27,9	Power consumption in stand-by mode (Ps)	0,49 W
Fluid Dynamic Efficiency class (FDEC)	B	Time increase factor (F)	1,00
Lighting Efficiency (LE)	84,1 lux/W	Energy Efficiency Index per first cavity	58,2
Lighting Efficiency Class (LEC)	A	Measured air flow rate at best efficiency point (Qbep)	373 m³/h
Grease Filtering Efficiency (GFE)	78,7 %	Measured air pressure at best efficiency point (Qbep)	430 Pa
Grease Filtering Efficiency Class (GFEC)	C	Measured electric power input at best efficiency point (Wbep)	160 W
Air flow at minumum speed (Qmin)	295 m³/h	Normal Power of the light system (WI)	2 W
Maximum extraction rate	513 m³/h	Average illumination of the light on the cooking surface (Emiddle)	370 lux
Intensive extraction rate	702 m³/h	Sound power level at highest setting (Lwa)	64 dBA
Airbourne acouistical A-weighted sound Power Emission at minimum speed (SPEmin)	51 dBA		

Electrical Connection

Nominal power	278 W	Frequency (Hz)	50-60 Hz
Voltage	220-240 V	Power supply cable length	1000 mm

Also available

Alternative colours available

Stainless steel, Cream

Available colours

KS110XE - KS110PE

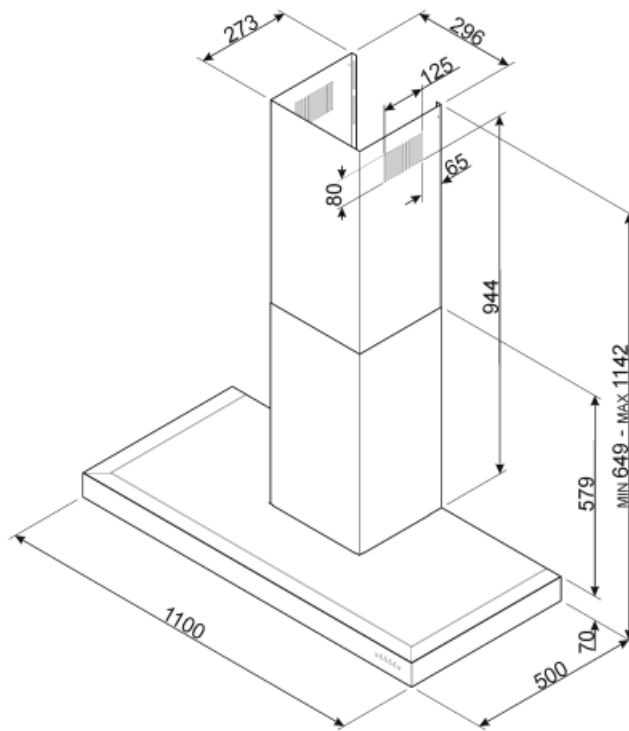

Not included accessories

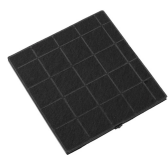

FLT4







Charcoal filter Kit 1 piece



KITALLFC

Universal Charcoal filter Stainless Steel AISI 304 The filter can be washed in dishwasher 50 °C (water and suitable detergent) and to dry it put in the oven 180°C 25 minutes

Symbols glossary

- | | | | |
|--|---|---|--|
|  | Filters: Model has filters to help remove grease from the steam emanating from the pans during cooking. |  | Switch off automatically: A special setting, to run after the end of cooking for a pre-set time and then switch off automatically. |
|  | Warning light(s): to advise when filters need changing. |  | Lights: All cooker hoods feature lights to illuminate the cooking area or add to the ambience of the kitchen. |
|  | Intensive/turbo setting: when extra fast extraction is required. |  | |