

KSA600HXE

Product family	Hood
Tipo de Exaustor	Decorative wall hood
Design	Chimney
Extraction	Extraction
Electronic control	Yes
Perimeter extraction	No
Material	Stainless steel
Type of steel	Brushed
EAN code	8017709201586
Aesthetic	Universal
Colour	Stainless steel
Acabamento	Satin
Cor da serigrafia	Serigrafia em preto
Logotipo	Logotipo serigrafado



Controls



Control setting	Electronic buttons	Display	1 a LED
------------------------	--------------------	----------------	---------

Program / Functions

No. of speeds	3
Intensive speed	
24h air filter function	No
Other functions	No
Time-setting options	No
Other options	No
Ventilação automática	No

Technical Features

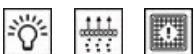

Hood without motor	No	No. of filters	2
Remote motor	No	Anti-grease filters	Aluminium
No. of lights	2	Charcoal filters included	No
Light type	LED	Filter replacement indicator	Yes
Light Power	2 W	Vent outlet	150 mm
Dimmer mode	No	Minimum distance from GAS hob	650 mm
Escala de temperatura de cor clara (°K)	3500 °K		

Free outlet maximum capacity	650 m ³ /h	Minimum distance from ELECTRIC hob	500 mm
Motor power	250 W	Non return valve	Yes

	Extraction rate IEC 61591 [m ³ /h]	Noise level IEC 60704-2-13 [dBA]
Speed 1	256	51
Speed 2	368	57
Speed 3	448	61
Intensive speed	603	66

Accessories Included

Remote control	No	Tube reduction	No
Sliding door	No		

Performance / Energy Label



Consumo anual de energía (CAE exaustor)	74 kWh/a	Airborne acoustical A-weighted sound Power Emission at maximum speed (SPEmax)	61 dBA
Energy efficiency class (EEC)	B	Airbourne acoustical A-weighted sound power emission at boost speed (SPEboost)	66 dBA
Fluid Dynamic Efficiency (FDE)	22,8	Power consumption in stand-by mode (Ps)	0,49 W
Fluid Dynamic Efficiency class (FDEC)	B	Time increase factor (F)	1,2
Lighting Efficiency (LE)	29 lux/W	Energy Efficiency Index	69,5
Lighting Efficiency Class (LEC)	A	Measured air flow rate at best efficiency point (Qbep)	288 m ³ /h
Grease Filtering Efficiency (GFE)	76 %	Measured air pressure at best efficiency point (Pbep)	454 Pa
Grease Filtering Efficiency Class (GFEC)	C	Measured electric power input at best efficiency point (Wbep)	160 W
Air flow at minumum speed (Qmin)	256 m ³ /h	Nominal Power consumption of the light system (WL)	5 W
Air flow at maximum speed (Qmax)	448 m ³ /h	Average illumination of the light on the cooking surface (Emiddle)	145 lux
Air flow at boost speed (Qboost)	603 m ³ /h	Sound power level at highest setting (Lwa)	61 dBA
Airbourne acoustical A-weighted sound Power Emission at minimum speed (SPEmin)	51 dBA		

Electrical Connection

Plug	No	Frequency (Hz)	50-60 Hz
Electrical connection rating	255 W	Comprimento do cabo de alimentação	1500 mm
Voltage	220-240 V		

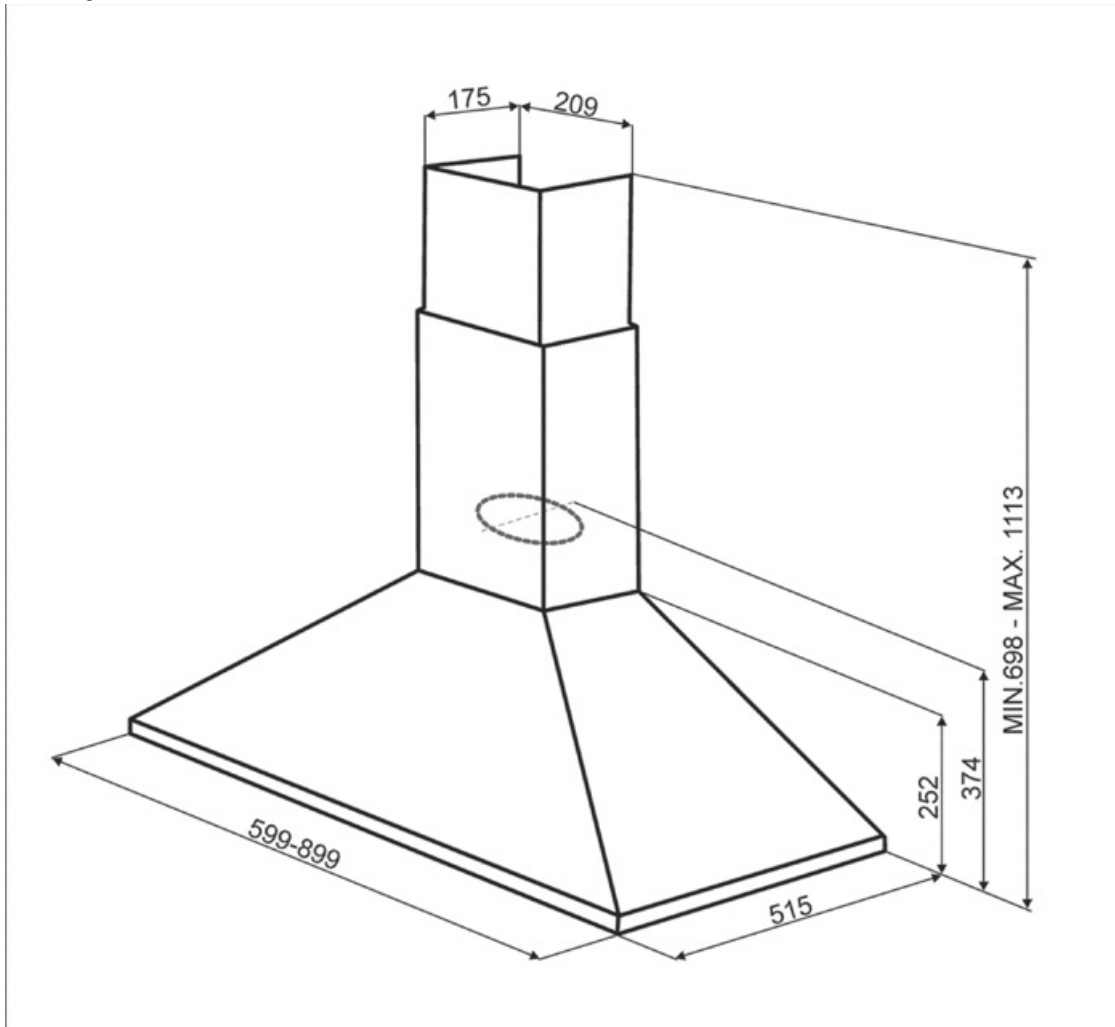

Symbols glossary



Filtros: O modelo tem filtros para ajudar a remover a graxa do vapor que emana das panelas durante o cozimento.



Display LED: para mostrar os programas, funções e opções selecionadas e o tempo até ao final do ciclo.



Luz(s) de aviso: para avisar quando os filtros precisam ser trocados.



Luzes: Todos os exaustores possuem luzes para iluminar a área de cozinhar ou adicionar ao ambiente da cozinha.



Configuração intensiva/turbo: quando a extração extra rápida é necessária.