

# KSET51E2

Product family	Hood
Tipo de Exaustor	Integrated (semi) hood
Design	Telescopic
Extraction	Extraction
Electronic control	No
Perimeter extraction	No
Material	Painted material
EAN code	8017709309077
Aesthetic	Universal
Colour	Silver
Acabamento	Silver
Cor da serigrafia	Serigrafia em preto
Logotipo	Logotipo serigrafado



## Controls

Control setting	Slider
-----------------	--------

## Program / Functions

No. of speeds	3
Intensive speed	No
24h air filter function	No
Other functions	No
Time-setting options	No
Other options	No
Ventilação automática	No

## Technical Features



Remote motor	No	Anti-grease filters	Aluminium
No. of lights	2	Charcoal filters included	Yes
Light type	LED	Filter replacement indicator	No
Light Power	4 W	Vent outlet	120 mm
Dimmer mode	No	Minimum distance from GAS hob	650 mm
Free outlet maximum capacity	315 m <sup>3</sup> /h	Minimum distance from ELECTRIC hob	450 mm
Motor power	125 W	Non return valve	No
No. of filters	2		

	Extraction rate IEC 61591 [m³/h]	Noise level IEC 60704-2-13 [dBA]
Speed 1	180	57
Speed 2	220	62
Speed 3	310	67

## Accessories Included

Remote control	No	Tube reduction	No
Sliding door	No		

## Performance / Energy Label



Consumo anual de energia (CAE exaustor)	70 kWh/a	Airbourne acoustical A-weighted sound Power Emission at minimum speed (SPEmin)	57 dBA
Energy efficiency class (EEC)	D	Airborne acoustical A-weighted sound Power Emission at maximum speed (SPEmax)	67 dBA
Fluid Dynamic Efficiency (FDE)	8,1	Time increase factor (F)	1,7
Fluid Dynamic Efficiency class (FDEC)	E	Energy Efficiency Index	91,4
Lighting Efficiency (LE)	13 lux/W	Measured air flow rate at best efficiency point (Qbep)	164 m³/h
Lighting Efficiency Class (LEC)	D	Measured air pressure at best efficiency point (Pbep)	183 Pa
Grease Filtering Efficiency (GFE)	75,1 %	Measured electric power input at best efficiency point (Wbep)	103 W
Grease Filtering Efficiency Class (GFEC)	C	Nominal Power consumption of the light system (WL)	8 W
Air flow at minumum speed (Qmin)	180 m³/h	Average illumination of the light on the cooking surface (Emiddle)	100 lux
Air flow at maximum speed (Qmax)	310 m³/h	Sound power level at highest setting (Lwa)	67 dBA

## Electrical Connection

Plug	(F;E) Schuko	Frequency (Hz)	50 Hz
Electrical connection rating	133 W	Comprimento do cabo de alimentação	1000 mm
Voltage	220-240 V		

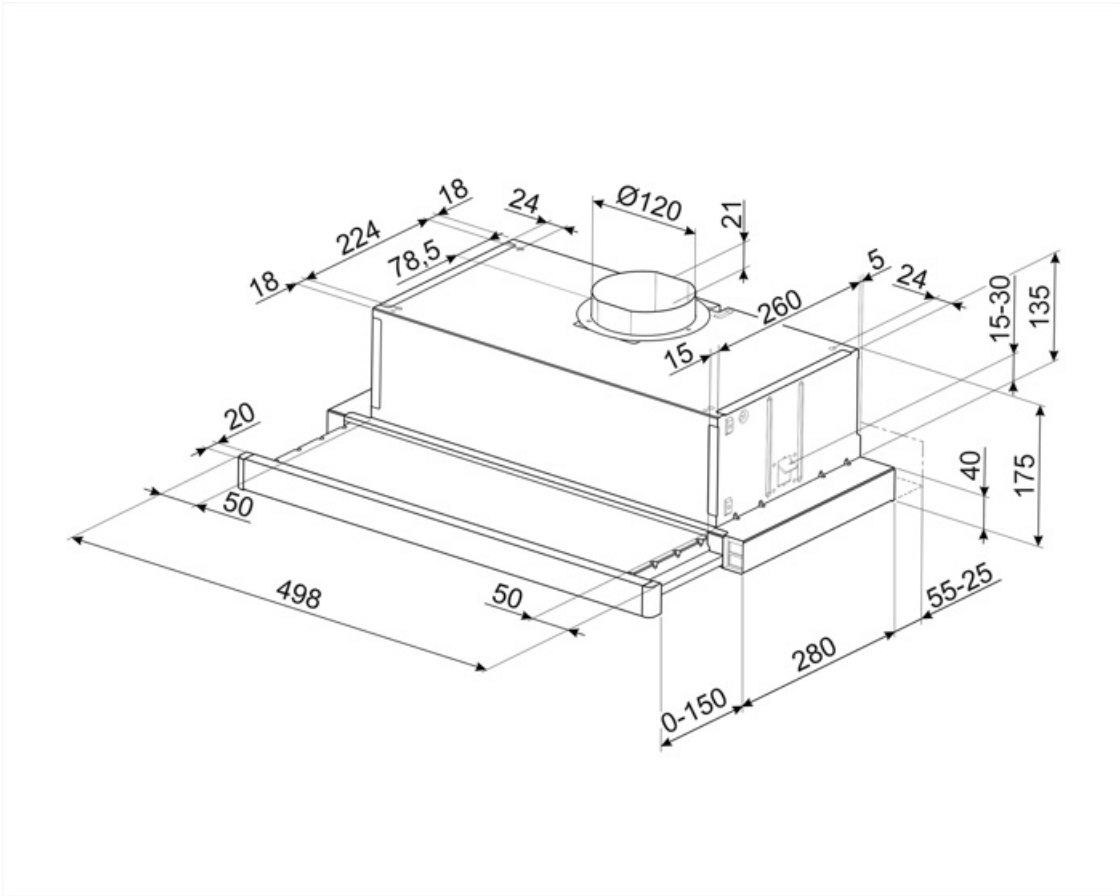

---

## Symbols glossary

---



Filtros: O modelo tem filtros para ajudar a remover a graxa do vapor que emana das panelas durante o cozimento.



Filtros de carvão: Extrair através de filtros de carvão ou diretamente para o exterior diminui consideravelmente os fortes odores de cozimento.



Luzes: Todos os exaustores possuem luzes para iluminar a área de cozinhar ou adicionar ao ambiente da cozinha.