

KSET600HXE

Product family	Hood
Hood Type	Telescopic Cooker Hoods
Design	Telescopic
Extraction	Ducted out or re-circulation possible
Electronic control	Yes
Material	Stainless steel
Type of steel	Brushed
EAN code	8017709205386
Aesthetics	Universal
Colour	Stainless steel
Finishing	Brushed
Serigraphy colour	Black
Logo	Silk screen



Controls

Control setting	Electronic buttons
-----------------	--------------------

Program / Functions

No. of speeds	3
Intensive speed	

Technical Features

			
No. of lights	2	No. of filters	2
Light type	LED	Anti-grease filters	Aluminium
Light power	2 W	Vent outlet	150 mm
Light colour	3500 °K	Minimum distance from GAS hob	650 mm
Free outlet maximum capacity	610 m ³ /h	Minimum distance from ELECTRIC hob	500 mm
Motor power	220 W	Non return valve	Yes

	Extraction rate IEC 61591 [m ³ /h]	Noise level IEC 60704-2-13 [dBA]
Speed 1	256	48
Speed 2	332	53
Speed 3	496	63

Intensive speed	603	68
-----------------	-----	----

Accessories Included

Tube reduction Yes

Performance / Energy Label



Annual Efficiency Consumption (AEChood)	45 KWh/year	Airbourne acoustical A-weighted sound Power Emission at minimum speed (SPEmin)	48 dBA
Energy efficiency class (EEC)	A	Airborne acoustical A-weighted sound Power Emission at maximum speed (SPEmax)	63 dBA
Fluid Dynamic Efficiency (FDE)	30.9	Airbourne acoustical A-weighted sound power emission at boost speed (SPEboost)	68 dBA
Fluid Dynamic Efficiency class (FDEC)	A	Power consumption in stand-by mode (Ps)	0.49 W
Lighting Efficiency (LE)	29 lux/W	Time increase factor (F)	0.9
Lighting Efficiency Class (LEC)	A	Measured air flow rate at best efficiency point (Qbep)	336 m ³ /h
Grease Filtering Efficiency (GFE)	76 %	Measured air pressure at best efficiency point (Qbep)	414 Pa
Grease Filtering Efficiency Class (GFEC)	C	Measured electric power input at best efficiency point (Wbep)	125 W
Air flow at minumum speed (Qmin)	256 m ³ /h	Normal Power of the light system (WI)	5 W
Maximum extraction rate	496 m ³ /h	Average illumination of the light on the cooking surface (Emiddle)	145 lux
Intensive extraction rate	603 m ³ /h	Sound power level at highest setting (Lwa)	63 dBA

Electrical Connection

Nominal power	225 W	Frequency (Hz)	50-60 Hz
Voltage	220-240 V	Power supply cable length	1500 mm

Optional accessories

Charcoal filter KITFC500

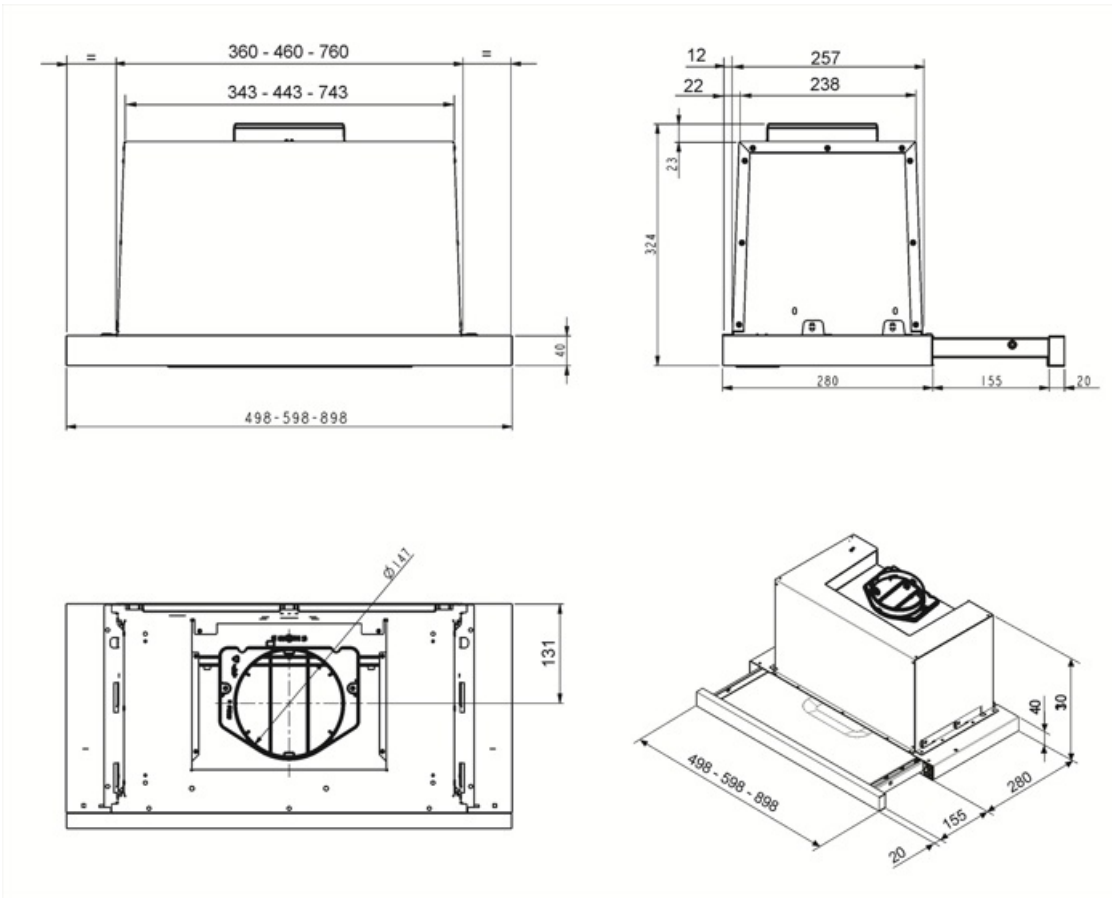

Compatible Accessories



KITFC500

Round Charcoal filters (kit 2 pieces)

Symbols glossary



Filters: Model has filters to help remove grease from the steam emanating from the pans during cooking.



Lights: All cooker hoods feature lights to illuminate the cooking area or add to the ambience of the kitchen.



A: Product drying performance, measured from A+++ to D / G depending on the product family



Intensive/turbo setting: when extra fast extraction is required.