

KSET666XE

Product family	Hood
Tipo de Exaustor	Integrated (semi) hood
Design	Telescopic
Extraction	Extraction
Electronic control	No
Perimeter extraction	No
Material	Stainless steel
Type of steel	Brushed
EAN code	8017709235116
Aesthetic	Universal
Colour	Silver
Cor da serigrafia	Serigrafia em preto
Logotipo	Logotipo serigrafado





Controls

Control setting	Buttons
-----------------	---------

Program / Functions

No. of speeds	3
Intensive speed	No
24h air filter function	No
Other functions	No
Time-setting options	No
Other options	No

Technical Features

			
Hood without motor	No	No. of filters	2
Remote motor	No	Anti-grease filters	Aluminium
No. of lights	2	Charcoal filters included	No
Light type	LED	Filter replacement indicator	No
Light Power	2.5 W	Vent outlet	150 mm
Dimmer mode	No	Minimum distance from GAS hob	650 mm
Escala de temperatura de cor clara (°K)	3500 °K	Minimum distance from ELECTRIC hob	430 mm
Free outlet maximum capacity	664 m ³ /h	Non return valve	Yes
Motor power	200 W		

	Extraction rate IEC 61591 [m ³ /h]	Noise level IEC 60704-2-13 [dBA]
Speed 1	256	46
Speed 2	377	55
Speed 3	647	67

Accessories Included

Remote control	No	Tube reduction	Yes
Sliding door	No		

Performance / Energy Label



Consumo anual de energia (CAE exaustor)	39 kWh/a	Airbourne acoustical A-weighted sound Power Emission at minimum speed (SPEmin)	46 dBA
Energy efficiency class (EEC)	A	Airborne acoustical A-weighted sound Power Emission at maximum speed (SPEmax)	67 dBA
Fluid Dynamic Efficiency (FDE)	33,5	Time increase factor (F)	1,00
Fluid Dynamic Efficiency class (FDEC)	A	Measured air flow rate at best efficiency point (Qbep)	336 m ³ /h
Lighting Efficiency (LE)	29 lux/W	Measured air pressure at best efficiency point (Pbep)	434 Pa
Lighting Efficiency Class (LEC)	A	Measured electric power input at best efficiency point (Wbep)	121 W
Grease Filtering Efficiency (GFE)	66 %	Nominal Power consumption of the light system (WL)	5 W
Grease Filtering Efficiency Class (GFEC)	D	Average illumination of the light on the cooking surface (Emiddle)	145 lux
Air flow at minumum speed (Qmin)	256 m ³ /h	Sound power level at highest setting (Lwa)	67 dBA
Air flow at maximum speed (Qmax)	647 m ³ /h		

Electrical Connection

Plug	No	Frequency (Hz)	50-60 Hz
Electrical connection rating	205 W	Comprimento do cabo de alimentação	1500 mm
Voltage	220-240 V		

Optional accessories

Charcoal filter	KITFC400
Remote control	No
Chimney extension	No
Vent outlet	No

Non return valve	Yes
Kit with aesthetic components	No
Diffuser kit	No

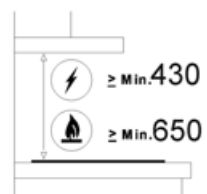
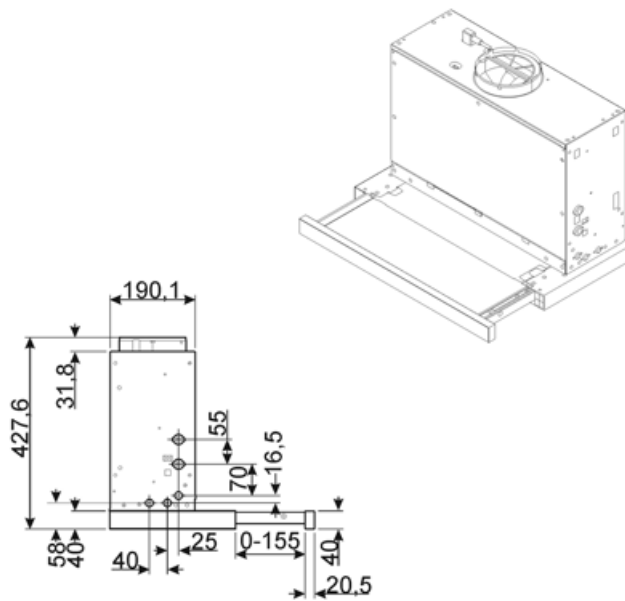
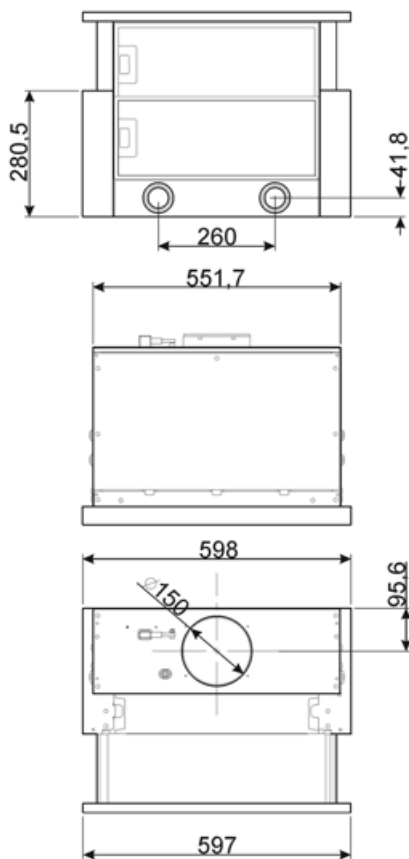

Compatible Accessories

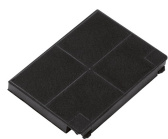

KITFC400

Kit filtros de carvão 2 peças

Symbols glossary



Filtros: O modelo tem filtros para ajudar a remover a graxa do vapor que emana das panelas durante o cozimento.



Luzes: Todos os exaustores possuem luzes para iluminar a área de cozinhar ou adicionar ao ambiente da cozinha.



R: Desempenho de secagem do produto, medido de A++ a D/G, dependendo da família de produtos