

KSG6P4X







Product familie	Dampkap
Type dampkap	Inbouwdampkap
Type dampkap	Volledig integreerbaar
Extractie	Extractie
Elektronische bediening	Ja
Randafzuiging	Ja
Materiaal	Inox
Type staal	Geborsteld inox
EAN-code	8017709319366
Design	Universeel
Kleur	Inox
Afwerking	Geborsteld inox
Logo	Geëtst



Bediening

Bediening	Touch bediening met witte LED	LED kleur	Wit
-----------	-------------------------------	-----------	-----

Program / Functions

Aantal snelheden	3
Snelheid Intensief	
Luchtzuiveringsfunctie (24 uur)	
Automatische uitschakeling	
Auto-Vent 2.0	

Technische specificaties



Aantal lampen	2	Aantal filters	2
Type lamp	LED	Vetfilters	Aluminium
Vermogen lamp	2.3 W	Indicator vervangen filter	Ja
Dimmerfunctie	Ja	Diameter ventilatie outlet	150 mm
Temperatuur licht aanpasbaar	2700° - 4000° K	Minimum afstand van gaskookplaat	650 mm
Capaciteit P0	730 m ³ /h	Minimum afstand van elektrische kookplaat	650 mm
Vermogen motor	230 W		

Terugslagklep

Ja

	Capaciteit niveau 1 (IEC 61591) [m ³ /h]	Geluidsniveau niveau 1 (IEC 60704-2-13) [dBA]
Snelheid 1	265	49
Snelheid 2	360	56
Snelheid 3	484	61
Snelheid Intensief	660	67

Prestaties / energielabel



Jaarlijkse energieconsumptie (AEC)	58 KWh/jaar	Akoestische A-gewogen geluidsemisatie op maximum snelheid	62 dBA
Energie-efficiëntieklasse (EEC)	B	Akoestische A-gewogen geluidsvermogens in de lucht met intensieve snelheid	67 dBA
Hydrodynamische efficiëntieklasse (FDE)	27,9	Vermogensverbruik in Off modus (Po)	0,49 W
Hydrodynamische efficiëntieklasse (FDEC)	B	Tijdverhogingsfactor (F)	1,0
Licht Efficiëntie (LE)	39,3 lux/W	Energie-efficiëntie Index	58
Licht Efficiëntieklasse (LEC)	A	Gemeten luchtdebiet op het beste efficiëntiepunt (Qbep)	348 m ³ /h
Vetfilter Efficiëntie (GFE)	74,9 %	Gemeten luchtdruk op het beste efficiëntiepunt (Pbep)	433 Pa
Vetfilter Efficiëntieklasse (GFEC)	D	Gemeten elektrisch vermogen op het beste efficiëntiepunt (Wbep)	150 W
Debiet luchtafvoer op minimum snelheid (Qmin)	265 m ³ /h	Nominaal energieverbruik van de verlichting (WL)	5 W
Luchtstroom bij maximale snelheid (Qmax)	484 m ³ /h	Gemiddelde verlichting op het kookoppervlak (Emiddle)	181 lux
Luchtstroom bij intensieve snelheid (Qboost)	660 m ³ /h	Geluidsniveau bij de hoogste instelling (Lwa)	62 dBA
Akoestische geluidsdruk op minimum snelheid (SPEmin)	49 dBA		

Elektrische aansluiting

Nominale aansluitwaarde	235 W	Frequentie	50-60 Hz
Spanning	220-240 V	Lengte voedingskabel	1500 mm

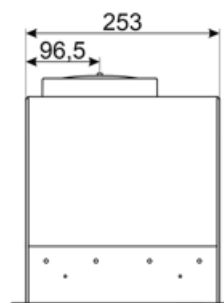
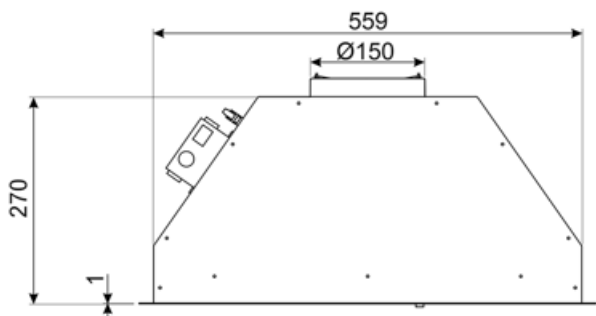
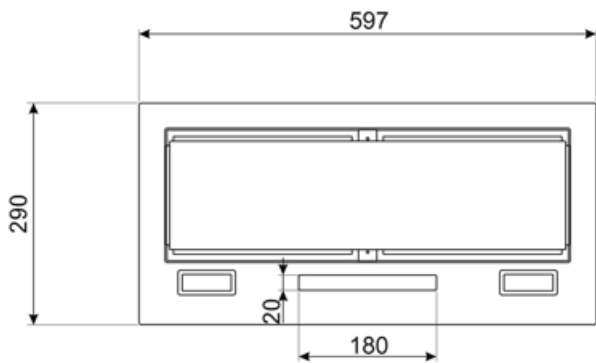

Compatible Accessories

FLT6











Round Charcoal filters (kit 2 pieces)



KITALLFC

Universal Charcoal filter Stainless Steel AISI 304 The filter can be washed in dishwasher 50 °C (water and suitable detergent) and to dry it put in the oven 180°C 25 minutes

Symbols glossary

	24h: When selected this function refreshes the air for c. 10 minutes every hour over a 24 hour period, at minimum speed and an imperceptible noise level.		Filters: Model has filters to help remove grease from the steam emanating from the pans during cooking.
	Connection between hob and hood		Automatisch uitschakelen: Een speciale instelling, om na het einde van de bereiding een vooraf ingestelde tijd te laten lopen en daarna automatisch uit te schakelen.
			Dimmering Lights
	Warning light(s): to advise when filters need changing.		Lights: All cooker hoods feature lights to illuminate the cooking area or add to the ambience of the kitchen.
	Perimeter extraction panels: very efficient and aid noise reduction.		Intensive/turbo setting: when extra fast extraction is required.
	Tunable white from warm to cold		