

KSG74B



Product family	Hood
Tipo de Exaustor	Integrated hood
Design	Fully integrated
Extraction	Extraction
Electronic control	Yes
Perimeter extraction	Yes
Material	Stainless Steel + Glass
Type of steel	Brushed
EAN code	8017709226183
Hood width	
Aesthetic	Universal
Colour	Stainless steel
Acabamento	Glass
Glass Type	White
Cor da serigrafia	Serigrafia em cinzento
Logotipo	Logotipo serigrafado



Controls

Control setting	Electronic buttons	Led color	White
-----------------	--------------------	-----------	-------

Program / Functions

No. of speeds	3
Intensive speed	
24h air filter function	No
Other functions	No
Time-setting options	
Other options	No
Ventilação automática	No

Technical Features



Hood without motor	No	No. of filters	1
Remote motor	No	Anti-grease filters	stainless steel 7 layer
No. of lights	2	Charcoal filters included	No
Light type	LED	Filter replacement indicator	No
Light Power	1 W	Vent outlet	150 mm
Dimmer mode	No	Minimum distance from GAS hob	650 mm
Escala de temperatura de cor clara (°K)	4000 °K		

Free outlet maximum capacity	750 m ³ /h	Minimum distance from ELECTRIC hob	650 mm
Motor power	235 W	Non return valve	Yes

	Extraction rate IEC 61591 [m ³ /h]	Noise level IEC 60704-2-13 [dBA]
Speed 1	280	48
Speed 2	367	55
Speed 3	480	61
Intensive speed	700	68

Accessories Included

Remote control	No	Tube reduction	No
Sliding door	No		

Performance / Energy Label



Consumo anual de energía (CAE exaustor)	68 kWh/a	Airborne acoustical A-weighted sound Power Emission at maximum speed (SPEmax)	60 dBA
Energy efficiency class (EEC)	B	Airbourne acoustical A-weighted sound power emission at boost speed (SPEboost)	67 dBA
Fluid Dynamic Efficiency (FDE)	22,6	Power consumption in stand-by mode (Ps)	0,49 W
Fluid Dynamic Efficiency class (FDEC)	C	Time increase factor (F)	1,00
Lighting Efficiency (LE)	68 lux/W	Energy Efficiency Index	57,2
Lighting Efficiency Class (LEC)	A	Measured air flow rate at best efficiency point (Qbep)	344 m ³ /h
Grease Filtering Efficiency (GFE)	65,9 %	Measured air pressure at best efficiency point (Pbep)	437 Pa
Grease Filtering Efficiency Class (GFEC)	D	Measured electric power input at best efficiency point (Wbep)	154 W
Air flow at minumum speed (Qmin)	247 m ³ /h	Nominal Power consumption of the light system (WL)	2 W
Air flow at maximum speed (Qmax)	450 m ³ /h	Average illumination of the light on the cooking surface (Emiddle)	118 lux
Air flow at boost speed (Qboost)	592 m ³ /h	Sound power level at highest setting (Lwa)	60 dBA
Airbourne acoustical A-weighted sound Power Emission at minimum speed (SPEmin)	47 dBA		

Electrical Connection

Plug	No	Frequency (Hz)	50-60 Hz
Electrical connection rating	238 W	Comprimento do cabo de alimentação	1000 mm
Voltage	220-240 V		

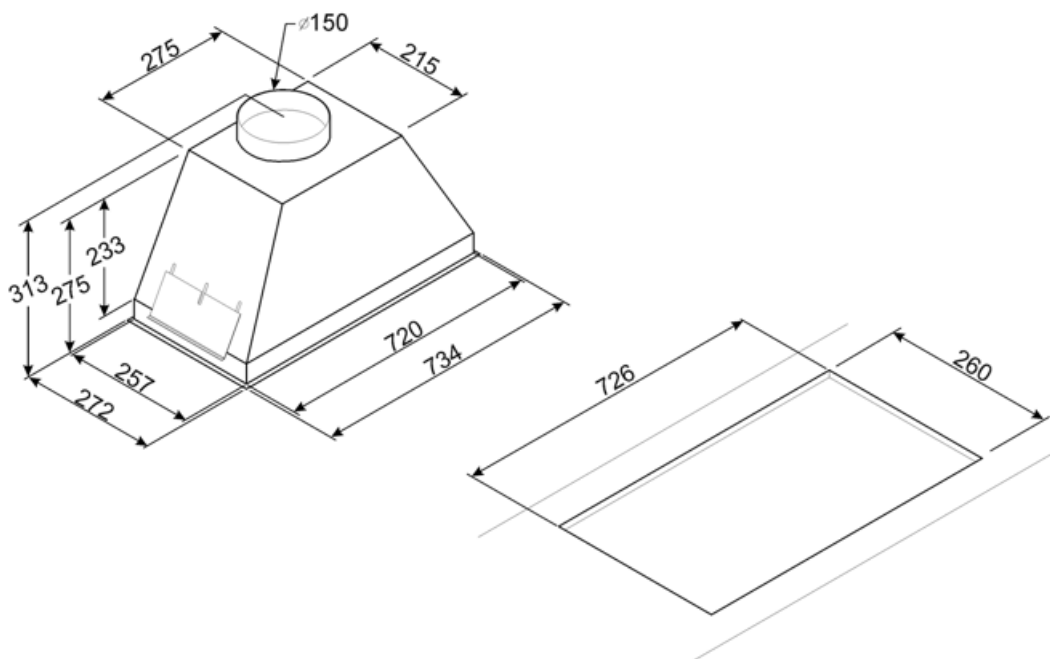

Symbols glossary



Filtros: O modelo tem filtros para ajudar a remover a graxa do vapor que emana das panelas durante o cozimento.



Luzes: Todos os exaustores possuem luzes para iluminar a área de cozinhar ou adicionar ao ambiente da cozinha.



Configuração intensiva/turbo: quando a extração extra rápida é necessária.



Desligar automaticamente: Uma configuração especial, para ser executada após o final do cozimento por um tempo pré-definido e, em seguida, desligar automaticamente.



Painéis de extração de perímetro: muito eficiente e ajuda na redução de ruído.



Benefit (TT)

Perimetral aspiration

Optimized extraction through the perimeter aspiration system

Perimeter aspiration enhances extraction efficiency by directing vapors along the edges of the panel beneath the filters, optimizing air capture

Dimmering & Tunable lights

Customized lighting with LED lights featuring adjustable intensity and color temperature, from warm to cool tones