

KSGT61X

Product family	Hood
Tipo de Exaustor	Integrated hood
Design	Fully integrated
Extraction	Extraction
Electronic control	Yes
Perimeter extraction	No
Material	Stainless steel
Type of steel	Brushed
EAN code	8017709322069
Aesthetic	Universal
Colour	Stainless steel
Acabamento	Satin
Logotipo	Logotipo serigrafado



Controls

Control setting	Control knobs
-----------------	---------------

Program / Functions

No. of speeds	3
Intensive speed	No
24h air filter function	No
Other functions	No
Time-setting options	
Other options	No
Ventilação automática	No

Technical Features



Hood without motor	No	No. of filters	2
Remote motor	No	Anti-grease filters	Aluminium
No. of lights	2	Charcoal filters included	No
Light type	LED	Filter replacement indicator	Yes
Light Power	2 W	Vent outlet	150 mm
Dimmer mode	No	Minimum distance from GAS hob	650 mm
Escala de temperatura de cor clara (°K)	4000 °K	Minimum distance from ELECTRIC hob	500 mm
Free outlet maximum capacity	600 m ³ /h		
Motor power	140 W		

Non return valve Yes

	Extraction rate IEC 61591 [m³/h]	Noise level IEC 60704-2-13 [dBA]
Speed 1	250	47
Speed 2	380	56
Speed 3	570	65

Accessories Included

Remote control No Tube reduction Yes

Performance / Energy Label



Consumo anual de energía (CAE exaustor)	82 kWh/a	Airbourne acoustical A-weighted sound Power Emission at minimum speed (SPEmin)	47 dBA
Energy efficiency class (EEC)	C	Airborne acoustical A-weighted sound Power Emission at maximum speed (SPEmax)	65 dBA
Fluid Dynamic Efficiency (FDE)	17,00	Time increase factor (F)	1,4
Fluid Dynamic Efficiency class (FDEC)	D	Energy Efficiency Index	51,7
Lighting Efficiency (LE)	77,0 lux/W	Measured air flow rate at best efficiency point (Qbep)	335 m³/h
Lighting Efficiency Class (LEC)	A	Measured air pressure at best efficiency point (Pbep)	288 Pa
Grease Filtering Efficiency (GFE)	75,1 %	Measured electric power input at best efficiency point (Wbep)	158 W
Grease Filtering Efficiency Class (GFEC)	C	Nominal Power consumption of the light system (WL)	2 W
Air flow at minumum speed (Qmin)	250 m³/h	Average illumination of the light on the cooking surface (Emiddle)	170 lux
Air flow at maximum speed (Qmax)	570 m³/h	Sound power level at highest setting (Lwa)	65 dBA

Electrical Connection

Plug No Frequency (Hz) 50-60 Hz

Electrical connection rating
Voltage

142 W
220-240 V

Comprimento do cabo de alimentação 1500 mm

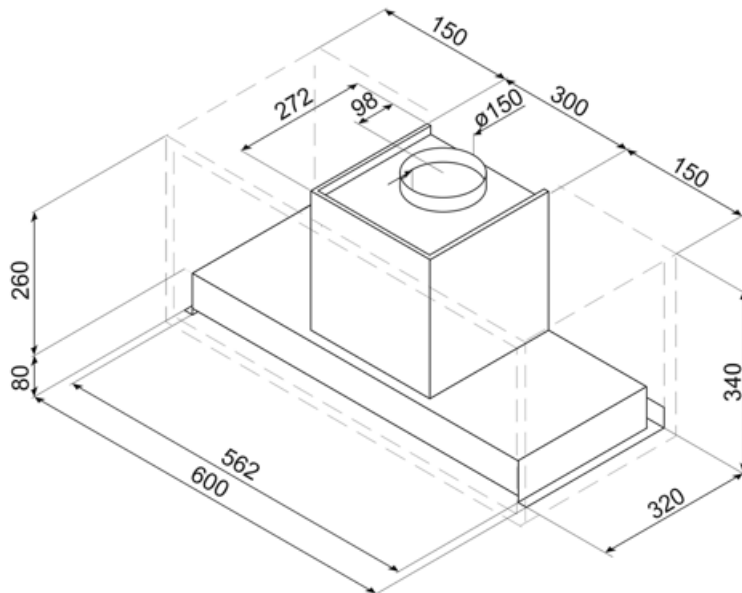

Compatible Accessories

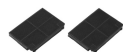

KITFC61

charcoal filter for KSGT61X

Symbols glossary



Filtros: O modelo tem filtros para ajudar a remover a graxa do vapor que emana das panelas durante o cozimento.



Luzes: Todos os exaustores possuem luzes para iluminar a área de cozinhar ou adicionar ao ambiente da cozinha.



Desligar automaticamente: Uma configuração especial, para ser executada após o final do cozimento por um tempo pré-definido e, em seguida, desligar automaticamente.



Luz(s) de aviso: para avisar quando os filtros precisam ser trocados.