

KSGT74X





Product family	Hood
Tipo de Exaustor	Integrated hood
Design	Fully integrated
Extraction	Extraction
Electronic control	Yes
Perimeter extraction	No
Material	Stainless steel
Type of steel	Brushed
EAN code	8017709328351
Aesthetic	Universal
Colour	Stainless steel
Acabamento	Satin
Logotipo	Logotipo embutido



Controls

Control setting	Controle de toque retroiluminado Branco	Led color	White
-----------------	--	-----------	-------

Program / Functions

No. of speeds	3
Intensive speed	
24h air filter function	
Other functions	No
Time-setting options	
Other options	No
Ventilação automática 2.0	
Ventilação automática 2.0	

Technical Features

						
Hood without motor	No	No. of filters	2			
Remote motor	No	Anti-grease filters	Stainless steel			
No. of lights	2	Charcoal filters included	No			
Light type	LED	Filter replacement indicator	Yes			
Light Power	2.3 W	Vent outlet	150 mm			
Dimmer mode	Yes					

Faixa de temperatura de cor clara	2700° - 4000° °K	Minimum distance from GAS hob	650 mm
Free outlet maximum capacity	820 m³/h	Minimum distance from ELECTRIC hob	500 mm
Motor power	275 W	Non return valve	Yes

	Extraction rate IEC 61591 [m³/h]	Noise level IEC 60704-2-13 [dBA]
Speed 1	254	48
Speed 2	442	61
Speed 3	603	68
Intensive speed	657	70

Accessories Included

Remote control	No	Tube reduction	No
-----------------------	----	-----------------------	----

Performance / Energy Label



Consumo anual de energia (CAE exaustor)	48 kWh/a	Airborne acoustical A-weighted sound Power Emission at maximum speed (SPEmax)	69 dBA
Energy efficiency class (EEC)	A	Airbourne acoustical A-weighted sound power emission at boost speed (SPEboost)	70 dBA
Fluid Dynamic Efficiency (FDE)	30,3	Power consumption in stand-by mode (Ps)	0,49 W
Fluid Dynamic Efficiency class (FDEC)	A	Time increase factor (F)	0,9
Lighting Efficiency (LE)	42,6 lux/W	Energy Efficiency Index	51,8
Lighting Efficiency Class (LEC)	A	Measured air flow rate at best efficiency point (Qbep)	329 m³/h
Grease Filtering Efficiency (GFE)	87,2 %	Measured air pressure at best efficiency point (Pbep)	448 Pa
Grease Filtering Efficiency Class (GFEC)	B	Measured electric power input at best efficiency point (Wbep)	135 W
Air flow at minumum speed (Qmin)	254 m³/h	Nominal Power consumption of the light system (WL)	5 W
Air flow at maximum speed (Qmax)	603 m³/h	Average illumination of the light on the cooking surface (Emiddle)	196 lux
Air flow at boost speed (Qboost)	657 m³/h	Sound power level at highest setting (Lwa)	69 dBA
Airbourne acouistical A-weighted sound Power Emission at minimum speed (SPEmin)	48 dBA		

Electrical Connection

Plug	No	Frequency (Hz)	50-60 Hz
Electrical connection rating	280 W	Comprimento do cabo de alimentação	1500 mm
Voltage	220-240 V		

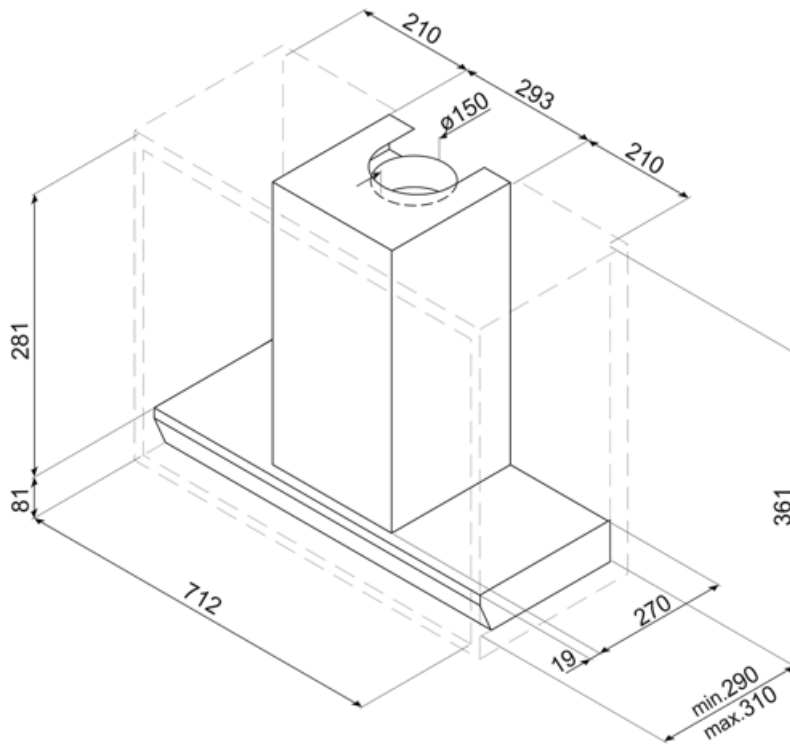

Compatible Accessories













KITALLFC

Filtro de carvão universal Aço inoxidável AISI 304 O filtro pode ser lavado na máquina lava-louça a 50 °C (água e detergente adequado) e para secar colocar no forno 180°C 25 minutos



KITFCGT74

Symbols glossary

-  24h: Quando selecionada, esta função refresca o ar durante cerca de 10 minutos a cada hora durante um período de 24 horas, a uma velocidade mínima e a um nível de ruído imperceptível.
-  Ligação entre a placa e o exaustor
-  R: Desempenho de secagem do produto, medido de A++ a D/G, dependendo da família de produtos
-  Luz(s) de aviso: para avisar quando os filtros precisam ser trocados.
-  Configuração intensiva/turbo: quando a extração extra rápida é necessária.
-  V-Condense System is a system that avoids the drips of condensation that you could show up on the hood within certain circumstance of use.
-  Filtros: O modelo tem filtros para ajudar a remover a graxa do vapor que emana das panelas durante o cozimento.
-  Desligar automaticamente: Uma configuração especial, para ser executada após o final do cozimento por um tempo pré-definido e, em seguida, desligar automaticamente.
-  Luzes de escurecimento
-  Luzes: Todos os exaustores possuem luzes para iluminar a área de cozinhar ou adicionar ao ambiente da cozinha.
-  Branco sintonizável do quente ao frio

Benefit (TT)

Touch display back lighted white

Intuitive and immediate usability thanks to the elegant white LED backlit touch display

Autovent 2.0

Centralized and practical control via Bluetooth connection between hob and hood

The Auto-Vent 2.0 system enables automatic hood management through connection with the hob: both appliances switch on simultaneously, and the extraction power adjusts in real time to the cooking intensity.

V-Condense System

Maximum cleanliness and protection with inclined anti-condensation baffle filters in stainless steel and integrated fixed collector

The V-Condense system collects the condensation forming on the filters, channeling it into the fixed collector integrated into the hood, preventing dripping onto the hob and ensuring maximum operating efficiency.