

# KTE60E2

Product family	Hood
Hood Type	Integrated (semi) hood
Design	Visible front panel
Extraction	Extraction
Material	Stainless steel
Type of steel	Brushed
EAN code	8017709333652
Hood width	60 cm
Aesthetic	Universale
Colour	Stainless steel
Finishing	Satin
Components finishing	Stainless steel
Serigraphy colour	Black
Logo	Silk screen

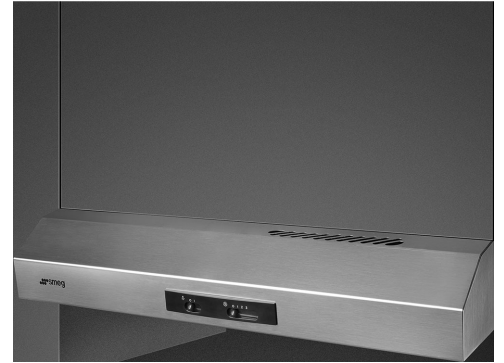



## Controls

Control setting	Slider
-----------------	--------

## Program / Functions

No. of speeds	3
---------------	---

## Technical Features

			
No. of lights	2	No. of filters	1
Light type	LED	Anti-grease filters	Aluminium
Light Power	6 W	Vent outlet	125 mm
Light color temperature scale (K)	2700 K	Minimum distance from GAS hob	650 mm
Free outlet maximum capacity	282 m <sup>3</sup> /h	Minimum distance from ELECTRIC hob	500 mm
Motor power	95 W		

	Extraction rate IEC 61591 [m <sup>3</sup> /h]	Noise level IEC 60704-2-13 [dBA]
Speed 1	124	44
Speed 2	153	51

Speed 3	266	62
------------	-----	----

## Performance / Energy Label



<b>Annual Efficiency Consumption (AEChood)</b>	55 kWh/a	<b>Airbourne acoustical A-weighted sound Power Emission at minimum speed (SPEmin)</b>	50 dBA
<b>Energy efficiency class (EEC)</b>	D	<b>Airborne acoustical A-weighted sound Power Emission at maximum speed (SPEmax)</b>	64 dBA
<b>Fluid Dynamic Efficiency (FDE)</b>	9,2	<b>Time increase factor (F)</b>	1
<b>Fluid Dynamic Efficiency class (FDEC)</b>	E	<b>Energy Efficiency Index</b>	1,7
<b>Lighting Efficiency (LE)</b>	20,1 lux/W	<b>Measured air flow rate at best efficiency point (Qbep)</b>	155 m <sup>3</sup> /h
<b>Lighting Efficiency Class (LEC)</b>	B	<b>Measured air pressure at best efficiency point (Pbep)</b>	175 Pa
<b>Grease Filtering Efficiency (GFE)</b>	65,1 %	<b>Measured electric power input at best efficiency point (Wbep)</b>	82 W
<b>Grease Filtering Efficiency Class (GFEC)</b>	D	<b>Nominal Power consumption of the light system (WL)</b>	6 W
<b>Air flow at minumum speed (Qmin)</b>	125 m <sup>3</sup> /h	<b>Average illumination of the light on the cooking surface (Emiddle)</b>	121 lux
<b>Air flow at maximum speed (Qmax)</b>	265 m <sup>3</sup> /h	<b>Sound power level at highest setting (Lwa)</b>	64 dBA

## Electrical Connection

<b>Electrical connection rating</b>	101 W	<b>Power supply cable length</b>	1500 mm
<b>Voltage</b>	220-240 V	<b>Plug</b>	Not present
<b>Frequency (Hz)</b>	50-60 Hz		

CAPPA	L <sup>-05</sup>
CM 60	599
CM 90	899



---

## Compatible Accessories

---



**KITFC550**

Charcoal filters Kit 1 piece

---

## Symbols glossary

---



**Filters:** Model has filters to help remove grease from the steam emanating from the pans during cooking.



**Lights:** All cooker hoods feature lights to illuminate the cooking area or add to the ambience of the kitchen.

