

KTS75SE2



Product family	Hood
Tipo de Exaustor	Decorative wall hood
Design	Angled
Extraction	Extraction
Electronic control	Yes
Perimeter extraction	No
Material	Stainless steel
Type of steel	Brushed
EAN code	8017709257279
Aesthetic	Linea
Colour	Stainless steel
Acabamento	Satin
Glass Type	Stopsol
Logotipo	Logotipo serigrafado



Controls

Control setting	Electronic buttons	Led color	White
-----------------	--------------------	-----------	-------

Program / Functions

No. of speeds	3
Intensive speed	
24h air filter function	No
Other functions	No
Time-setting options	
Other options	No
Ventilação automática	No

Technical Features



Hood without motor	No	No. of filters	1
Remote motor	No	Anti-grease filters	Stainless steel
No. of lights	2	Charcoal filters included	No
Light type	LED	Filter replacement indicator	Yes
Light Power	1 W	Vent outlet	150 mm
Dimmer mode	No	Minimum distance from GAS hob	427 mm
Escala de temperatura de cor clara (°K)	4000 °K	Minimum distance from ELECTRIC hob	427 mm
Free outlet maximum capacity	750 m ³ /h		

Motor power 275 W Non return valve Yes

	Extraction rate IEC 61591 [m ³ /h]	Noise level IEC 60704-2-13 [dBA]
Speed 1	278	56
Speed 2	303	63
Speed 3	549	65
Intensive speed	714	72

Accessories Included

Remote control No Tube reduction No
Sliding door No

Performance / Energy Label



Consumo anual de energía (CAE exaustor)	50 kWh/a	Airborne acoustical A-weighted sound Power Emission at maximum speed (SPEmax)	65 dBA
Energy efficiency class (EEC)	A	Airbourne acoustical A-weighted sound power emission at boost speed (SPEboost)	72 dBA
Fluid Dynamic Efficiency (FDE)	30,4	Power consumption in stand-by mode (Ps)	0,49 W
Fluid Dynamic Efficiency class (FDEC)	A	Time increase factor (F)	0,9
Lighting Efficiency (LE)	103,2 lux/W	Energy Efficiency Index	51,6
Lighting Efficiency Class (LEC)	A	Measured air flow rate at best efficiency point (Qbep)	364 m ³ /h
Grease Filtering Efficiency (GFE)	62,6 %	Measured air pressure at best efficiency point (Pbep)	437 Pa
Grease Filtering Efficiency Class (GFEC)	E	Measured electric power input at best efficiency point (Wbep)	146 W
Air flow at mininum speed (Qmin)	278 m ³ /h	Nominal Power consumption of the light system (WL)	2 W
Air flow at maximum speed (Qmax)	549 m ³ /h	Average illumination of the light on the cooking surface (Emiddle)	227 lux
Air flow at boost speed (Qboost)	714 m ³ /h	Sound power level at highest setting (Lwa)	65 dBA
Airbourne acoustical A-weighted sound Power Emission at minimum speed (SPEmin)	56 dBA		

Electrical Connection

Plug No Frequency (Hz) 50-60 Hz

Electrical connection rating 278 W
Voltage 220-240 V

Comprimento do cabo de alimentação 1000 mm

Also available

Outras cores disponíveis Branca, Preta

Códigos das outras cores disponíveis

KTS75SCE2 - KTS75BCE2 - KTS75NCE2

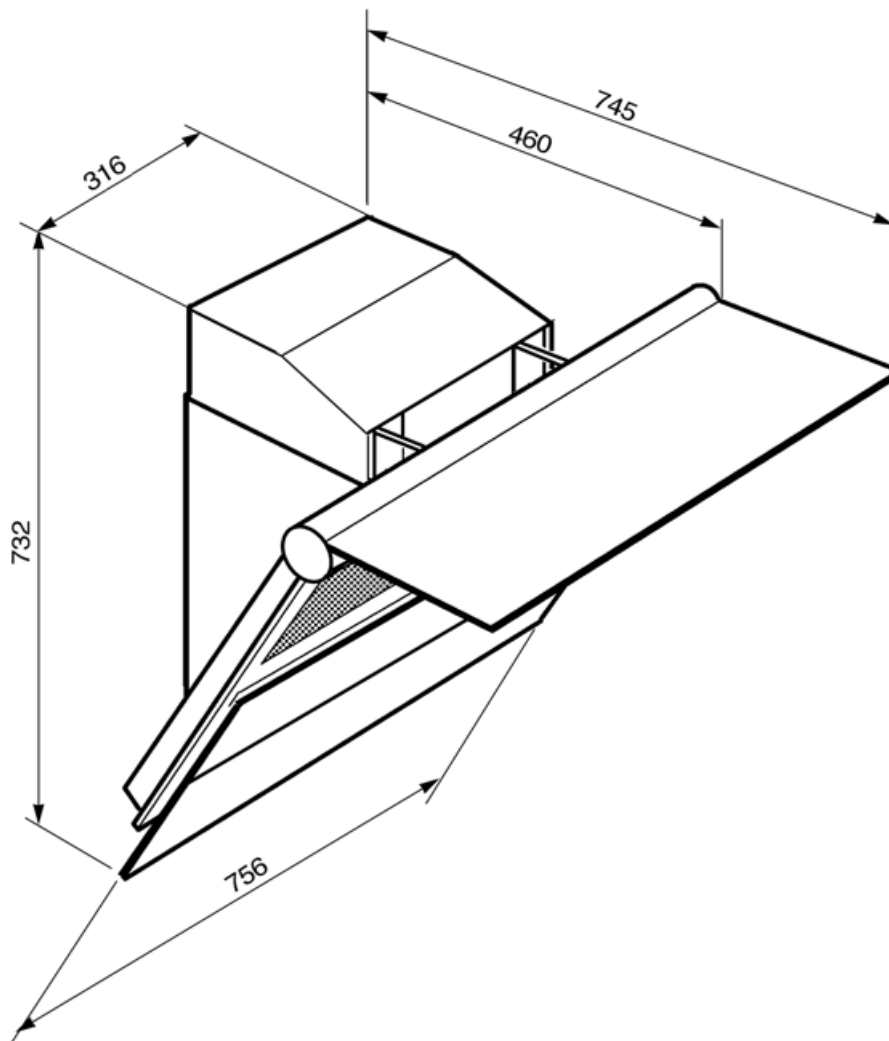



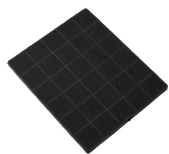



Compatible Accessories



KITFC906

Kit filtro de carvão 1 peça

Symbols glossary

- | | | | |
|--|---|---|--|
|  | Filtros: O modelo tem filtros para ajudar a remover a graxa do vapor que emana das panelas durante o cozimento. |  | Desligar automaticamente: Uma configuração especial, para ser executada após o final do cozimento por um tempo pré-definido e, em seguida, desligar automaticamente. |
|  | R: Desempenho de secagem do produto, medido de A++ a D/G, dependendo da família de produtos |  | Luz(s) de aviso: para avisar quando os filtros precisam ser trocados. |
|  | Luzes: Todos os exaustores possuem luzes para iluminar a área de cozinhar ou adicionar ao ambiente da cozinha. |  | Configuração intensiva/turbo: quando a extração extra rápida é necessária. |