

P261XGHNLK



Familie
Inbouw
Afmeting
Voeding
Type
EAN-code

Kookplaat
Standaard
60 cm
Gas
Gas
8017709239046



Design

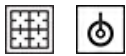

Esthetiek
Kleur
Afwerking
Materiaal
Type roestvrijstaal
Pannendragers
Branders
Materiaal branders
Type bediening
Positie bediening
Aantal bedieningsknoppen
Kleur knoppen
Logo
Kleur serigrafie

Selezione
Roestvrij staal
Geborsteld
Roestvrij staal
Geborsteld
Gietijzer
Smeg Contemporanea
Aluminium
Bedieningsknoppen
Voor
4
Zilver
Geëtst
Zwart

Program / Functions

Aantal kookzones gas	4
Totaal aantal kookzones	4

Opties



Worktop Cut-Out 478-482x555-560 mm

Technische specificaties

UR

Links - Gas - URP - 3.40 kW

Middenachter - Gas - SRD - 1.70 kW

Middenvoor - Gas - AUX - 1.10 kW

Rechts - Gas - RP - 2.50 kW

Thermobeveiliging Ja

Automatische
ontsteking Ja

Elektrische aansluiting

Aansluitwaarde 1 W
Spanning (V) 220-240 V
Type stroomkabel Eenfasig

Frequentie 50/60 Hz
Lengte voedingskabel 120 cm
Stekker (F;E) Schuko

Gasaansluiting

Type gas G25/G25.3 Natural gas
Gasaansluiting Conisch

Andere sproei-
ers meegeleverd G30 Vloeibaar gas GPL
Nominale
aansluitwaarde gas 8800 W

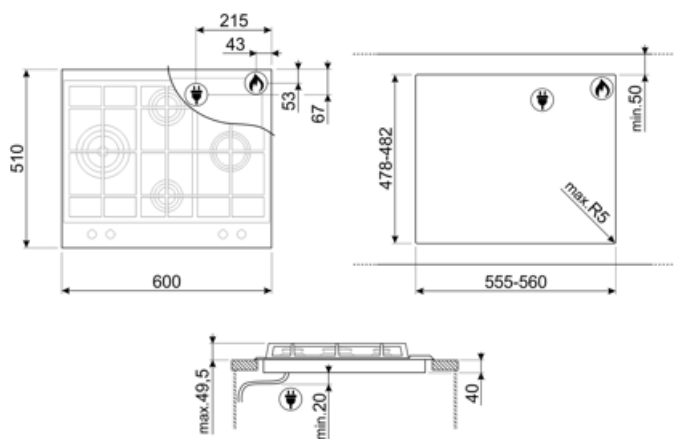

Compatibile Accessoire







GRW
Wok support



WOKGHU
Cast iron WOK Support

Symbols glossary

- | | | | |
|--|---|---|---|
|  | Standard installation: Traditional installation in tabletop, suitable for any kitchen sets. |  | Heavy duty gietijzeren pannendragers: voor maximale stabiliteit en sterkte. |
|  | CUT_OUT_STANDARD_72dpi |  | Ultrasnelle branders: Krachtige ultrasnelle branders bieden tot 5kw vermogen. |
|  | Knobs control | | |