

P272XGHNLK



Familie
Inbouw
Afmeting
Voeding
Type
EAN-code

Kookplaat
Standaard
70/75 cm
Gas
Gas
8017709239053



Design



Esthetiek
Kleur
Afwerking
Materiaal
Type roestvrijstaal
Pannendragers
Branders
Materiaal branders
Type bediening
Positie bediening
Aantal bedieningsknoppen
Kleur knoppen
Logo
Kleur serigrafie

Selezione
Roestvrij staal
Geborsteld
Roestvrij staal
Geborsteld
Gietijzer
Smeg Contemporanea
Aluminium
Bedieningsknoppen
Voor
6
Zilver
Geëtst
Zwart

Program / Functions

Aantal kookzones gas	5
Totaal aantal kookzones	5

Opties



Worktop Cut-Out 478-482x555-560 mm

Technische specificaties

UR

Linksvoor - Gas - AUX - 1.10 kW

Linksachter - Gas - RP - 2.50 kW

Midden - Gas - URP - 4.20 kW

Rechtsachter - Gas - SRD - 1.70 kW

Rechtsvoor - Gas - SRD - 1.70 kW

Thermobeveiliging Ja Automatische ontsteking Ja

Elektrische aansluiting

Aansluitwaarde	1 W	Frequentie	50/60 Hz
Spanning (V)	220-240 V	Lengte voedingskabel	120 cm
Type stroomkabel	Eenfasig	Stekker	(F;E) Schuko

Gasaansluiting

Type gas	G25/G25.3 Natural gas	Andere sproeiers meegeleverd	G30 Vloeibaar gas GPL
Gasaansluiting	Conisch	Nominale aansluitwaarde gas	11300 W

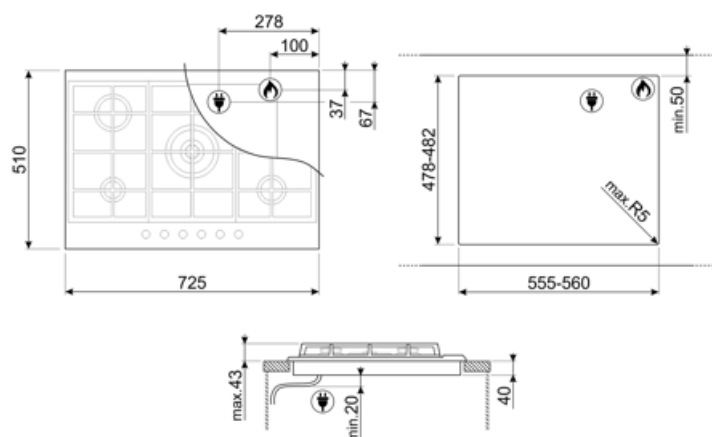

Compatibile Accessores







GRW
Wok support



WOKGHU
Cast iron WOK Support

Symbols glossary

- | | | | |
|--|---|---|---|
|  | Standard installation: Traditional installation in tabletop, suitable for any kitchen sets. |  | Heavy duty gietijzeren pannendragers: voor maximale stabiliteit en sterkte. |
|  | CUT_OUT_STANDARD_72dpi |  | Ultrasnelle branders: Krachtige ultrasnelle branders bieden tot 5kw vermogen. |
|  | Knobs control | | |