

# PDXF116RS



Familia	Encimera de cocción
Instalación	Cable
Dimensión	
Alimentación	
Tipología	Gas
Código EAN	8017709094614



## Estética



Estética	Clásica
Color	Acero inoxidable
Acabado	Satinado
Material	Acero inoxidable
Tipo de inox	Cepillado
Marco	
Color marco	
Rejillas	Parrillas de fundición
Quemadores	
Material de los quemadores	Aluminio
Tipo de regulación mandos	Mandos
Posición mandos	Lateral
N.º de mandos	4
Color mandos	Efecto inox
Acabado componentes	

## Programas/Funciones

Número de zonas de cocción a gas	4
Número total de zonas de cocción	4

## Características técnicas

Izquierda - Gas - AUX - 1.05 kW  
Central izquierda - Gas - RP - 2.50 kW

Central derecha - Gas - SRD - 1.75 kW

Derecha - Gas - SRD - 1.75 kW

Sistema de válvulas de seguridad **Sí**

## Conexión eléctrica

Datos nominales de conexión eléctrica	1 W	Frecuencia (Hz)	50/60 Hz
Tensión (V)	220-240 V		

## Conexión de gas

Tipo de gas	G20 gas natural	Datos nominales de conexión gas	7050 W
-------------	-----------------	---------------------------------	--------

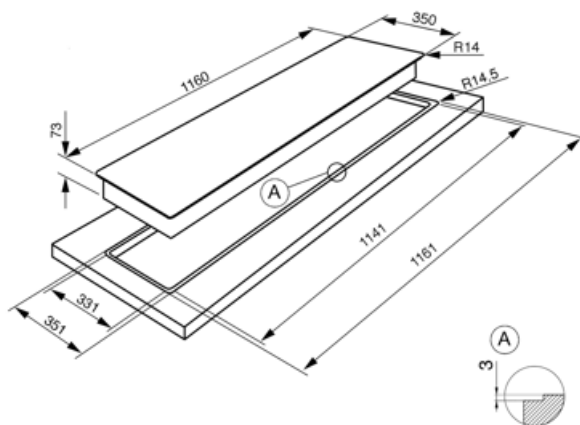

---

## Symbols glossary

---



Filotop: tipo de instalación que permite que la parte superior y el fregadero se integren perfectamente con la parte superior de la cocina.



Rejillas de hierro fundido: estas rejillas son resistentes a altas temperaturas. Sólidos y robustos, han sido diseñados para facilitar el movimiento y el reposicionamiento de las ollas en la superficie.



Knobs control

---

## Benefit (TT)

---

### **Gas hobs**

Consistent heat source control and easy, immediate temperature adjustment

Equipped with a thermocouple, the gas supply is cut off if the flame is extinguished for greater safety.

### **Inox**

Maximum resistance even at high temperatures: the stainless steel surface ensures durability and deformation resistance, withstanding thermal shocks without damage

### **Cast iron**

Solid and sturdy, easy to clean and maintain every day, thanks to the cast-iron pan supports—an emblem of long-lasting efficiency and durability.

Accurate power adjustment via knobs, for more precise cooking level control

### **Control knob position lateral**

Greater safety: side knob placement makes them hard to reach for children, reducing the risk of accidental ignition.

4 burners for every need: cook with precision and versatility thanks to different power levels, ideal for any pot and for managing multiple dishes simultaneously.

### **Gas safety valves**

Automatic protection against gas leaks: the thermocouple stops gas flow in the absence of flame, ensuring a safe environment even during unexpected shutdowns.