

# PX375

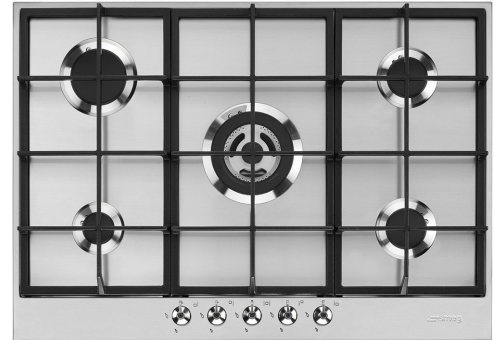

Product Family	Hob
Built-in type	Traditional
Dimensions	70/75 cm
Power supply	Gas
Type	Gas
EAN code	8017709252090



## Aesthetics



Aesthetic	Classica
Serie	New
Colour	Stainless steel
Finishing	Satin
Material	Stainless Steel
Type of steel	Brushed
Pan stands	Cast iron
Burners	Smeg Contemporary
Burners Material	Alluminium
Type of control setting	Control knobs
Control knob position	Front
No. of controls	5
Controls colour	Steel effect
Logo	Silk screen
Serigraphy colour	Black

## Program / Functions

No. of gas cook zones	5
Total no. of cook zones	5

## Options



Worktop Cut-Out	478-482x555-560 mm
-----------------	--------------------

## Technical Features

**UR**

Front-left - Gas - AUX - 1.10 kW  
 Rear-left - Gas - Rapid - 2.60 kW  
 Central - Gas - UR - 4.00 kW  
 Rear-right - Gas - Semi Rapid - 1.80 kW  
 Front-right - Gas - Semi Rapid - 1.80 kW  
**Gas safety valves** Yes

**Automatic Ignition** Yes

## Electrical Connection

**Electrical connection rating (W)** 1 W  
**Voltage (V)** 220-240 V  
**Type of electric cable installed** Yes, Single phase

**Frequency (Hz)** 50/60 Hz  
**Power supply cable length** 120 cm  
**Plug** Not present

## Gas Connection

**Gas Type** G20 Natural gas  
**Gas connection** Cilindrica  
**Other gas nozzles included** G30 GPL Liquid gas

**Other gas connections provided** Conical  
**Gas connection rating (W)** 11300 W

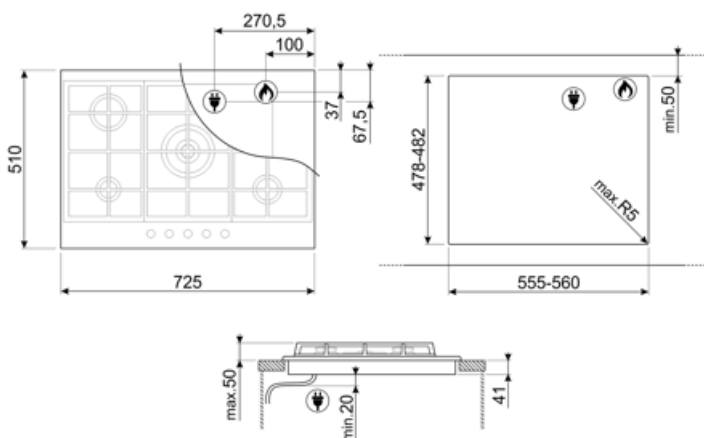

---

## Compatible Accessories

---



**GRW**  
Wok support



**WOKGHU**  
Cast iron WOK Support

---

## Alternative products

---

**PX375MB**

Colour: Matt Black



---

## Symbols glossary

---

- |  |   |   |   |
|--|---|---|---|
|  | Standard installation: Traditional installation in tabletop, suitable for any kitchen sets. |  | Heavy duty cast iron pan stands: for maximum stability and strength.        |
|  | CUT_OUT_STANDARD_72dpi  |  | Ultra rapid burners: Powerful ultra rapid burners offer up to 5kw of power. |
|  | Knobs control   |   |   |