

# RC19XDNMD



Product Family	Refrigerator
Installation	Free Standing
Category	Bottom Mount
Reference width	Until 60
Reference height	160 - 200
Cooling type	Total No Frost
Defrost	Automatic
Hinge type	Standard
Door opening flush with the wall	No
Slot-in	No
Hinge position	Right
Reversible door	Yes
EAN code	8017709343385



## Aesthetics



Aesthetic	Universal	Logotipo	Logotipo aplicado
Colour	Aspecto inox	Cor do perfil das prateleiras da porta	Silver
Material	Steel Effect	Cor do perfil das gavetas	Silver
Handle kit to be ordered separately	No	Cor do perfil da prateleira de vidro	Chrome
Handle	Integrated	Display	LED
Handle type	Fixed	Mostrar porções	Externo (na porta)
Logo colour	Chrome	Dispenser	No
Side material	Steel	Water Filter	No
Side colour	Silver	HomeBar	No

## Refrigerator compartment features



No. of adjustable shelves	2	Bottle shelf	Yes
Number of fruit and vegetables drawers	1	Type of crisper/vegetable drawers cover	Glass
Type of adjustable shelves	Glass	Life Plus zone-0°C	Yes
Type of crisper/vegetable drawers cover	On sliding rails	Internal light in fridge	Yes
Crisper Cover	Yes	Type of internal light (fridge)	LED

## Refrigerator Inner Door

Number of adjustable door shelves	2	No. of bottle shelves	1
Adjustable door shelves with wire support	No	Bottle shelves with wire support	No

## Other Refrigerator features



Accessories	Egg tray	Ionizer	Yes
Natural Plus Blu Light	No	Tecnologia de titânio	No
MultiFlow	Metal	Filtro de odor antibacteriano	No
Fan	No	Zona de cuidados biológicos	No

## Freezer compartment features

Number of drawers	3	Internal light in freezer	No
-------------------	---	---------------------------	----

## Freezer Inner Door

Pizza box	No
-----------	----

## Other Freezer features

Accessories	1 ice box	Fast freezing compartment	No
Manual ice maker	No	Ice tray shelf	No
Ice maker	No		

## Other technical features



Functions display	MultiZone	Fast freezing	No
Ligação à rede de água	Door open alarm		No
Temperature Alarm	Temperature Alarm		Yes
Type of temperature control	No. of compressors		Yes
Refrigerant gas type	Type of compressor		Electronic
Espuma expansiva de isolamento			1
			R600a
			Inverter
			Ciclopentano

## Etiqueta de Desempenho / Energia - Reg. 2019







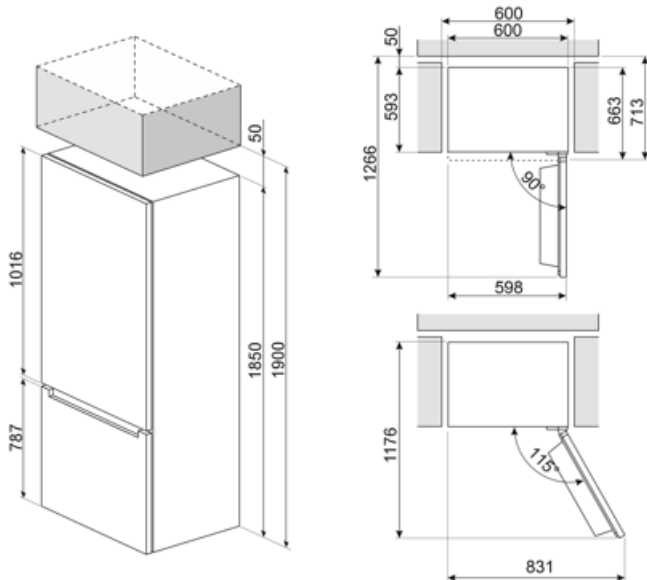

<b>Consumo de energia anual</b>	207 kWh/a	<b>Airborne acoustical noise emissions</b>	37 dB(A) re 1 pW
<b>Classe de eficiência energética</b>	D	<b>Autonomia de conservação sem energia elétrica</b>	9 h
<b>Classe de emissão de ruído acústico aerotransportado</b>	C	<b>4 estrelas - Capacidade de congelamento</b>	11.0 Kg/24h
<b>Volume líquido total</b>	326 l	<b>Classe climática</b>	SN, N, ST, T
<b>Soma dos volumes do(s) compartimento(s) congelado(s)</b>	106 l	<b>EEl</b>	80 %
<b>Soma dos volumes do(s) compartimento(s) refrigerado(s) e do(s) compartimento(s) não congelado(s)</b>	220 l		

## Electrical Connection

<b>Plug</b>	(F;E) Schuko	<b>Voltage (V)</b>	220-240 V
<b>Electrical connection rating</b>	200 W	<b>Frequency (Hz)</b>	50 Hz
<b>Current</b>	0,9 A	<b>Power supply cable length</b>	200 cm



## Symbols glossary

	Smeg Active Ion system improves the quality of the air inside the cell. Thanks to the generation of negatively charged ions released inside the fridge Active Ion system neutralizes unpleasant dust.		O sistema de descongelamento automático funciona descongelando automaticamente em intervalos regulares, eliminando a necessidade de descongelar completamente.
	Classe de eficiência energética D		Display LED: para mostrar os programas, funções e opções selecionadas e o tempo até ao final do ciclo.
	CONGELAMENTO RÁPIDO: A função de congelamento rápido reduz a temperatura do compartimento quando ativado algumas horas antes do uso.		Iluminação interior LED: é uma forma mais eficiente em termos energéticos e duradoura de iluminar o interior do aparelho.
	Life Plus 0°C: A temperatura nos compartimentos Lifeplus é mantida a 0°C, o que preserva a carne fresca e o peixe por mais tempo.		Tecnologia do inversor: A evolução dos secadores Smeg para modelos mais inteligentes e ambientalmente sustentáveis levou à escolha do uso da tecnologia do inversor com bombas de calor, o que reduz significativamente o consumo de energia.
	Multiflow Cooling System: the Multiflow ventilation system allows an even distribution of cool air around the fridge cabinet. The stainless steel panel gives a more premium look to the appliance.		

---

## Benefit (TT)

---

### **No-Frost system**

The No Frost system prevents the formation of ice and contributes to better preservation of food in the refrigerator

### **Metallic Multiflow system**

The metal Multiflow system ensures an even distribution of cold air inside the refrigerator, which diffuses through an elegant stainless steel panel

A back panel with a series of openings ensures uniform circulation of cold air around each shelf of the refrigerator. This advanced air recirculation system ensures a constant temperature and humidity level, preserving food freshness for longer and helping to reduce food waste significantly

### **Refrigerant gas R600a**

Environmentally friendly R600a refrigerant gas contributes to rapid cooling with lower energy consumption

### **Reversible door**

Reversible door ensures flexible installation and space optimisation

### **Life Plus 0°**

Temperature-controlled Life Plus compartment for optimal storage of specific food categories

### **Refrigerator Internal lighting**

Interior lighting for perfect visibility of shelves in the refrigerator compartment

### **Fruit and vegetable drawer**

The fruit and vegetable drawer ensures the best storage conditions for fresh food, avoiding any contamination

### **Inverter compressor**

Inverter compressor reduces noise and vibration levels for a quiet and comfortable kitchen environment

Inverter compressor technology offers significant advantages for refrigeration systems, improving both performance and efficiency. Better temperature control ensures a more stable and constant indoor environment, preserving the freshness of food. This technology also results in reduced energy consumption, as the compressor adjusts its speed according to cooling needs.

### **External display**

External display for simple and intuitive control with quick access to information