

# RI76RSI



Product Family	Refrigerator
Installation	Built-in
Category	Bottom Mount
Built-in niche	>200
Reference width	70 - 80
Reference height	Higher than 200
No-Frost system	Total
Cooling type	Fan assisted refrigerator, no-frost freezer
Defrost	Automatic
Hinge type	Door on door
Hinge position	Right
EAN code	8017709205102



## Aesthetics



Aesthetics	Universal	Side colour	Silver
Colour	Stainless steel	Logo	Silk screen
Design	Flat	Display	LCD
Material	Metal sheet	Display position	
Handle type	Fixed	Water Filter	Yes
Side material	Steel		

## Refrigerator compartment features



No. of adjustable shelves	3	Type of crisper/vegetable drawers cover	Glass
Number of fruit and vegetables drawers	1	Life Plus zone-0°C	Yes
Type of adjustable shelves	Glass	Internal light in fridge	Yes
Type of crisper/vegetable drawers cover	On sliding rails	Type of internal light (fridge)	LED
Crisper Cover	Yes		

## Refrigerator Inner Door

Number of adjustable door shelves	2	No. of bottle shelves	1
-----------------------------------	---	-----------------------	---

Adjustable door shelves with wire support Yes

Bottle shelves with wire support Yes

## Other Refrigerator features



MultiFlow

Yes

Ionizer

## Freezer compartment features

Number of drawers 2

Internal light in freezer Yes

Type of internal light (freezer) LED

Type of shelves Glass

## Other Freezer features

Accessories

Ice maker

Automatic

Ice tray shelf

Yes

## Other technical features



Functions display

Holiday, Fast freezing, Fast cooling, MultiZone, Control lock, Temperature alarm, Cooling timer, Demo Mode, Sabbath

MultiZone

Yes

Water network connection

Yes

Temperature alarm lamp

Yes

Door open alarm

Yes

Temperature Alarm

Acoustic and visual

Type of temperature control

Electronic

No. of compressors

2

Refrigerant gas type

R600a

Type of compressor

Variable Speed Compressor

Refrigerant Quantity (gr)

48 g

Foam agent

Cyclopentane

## Performance / Energy Label



Annual energy consumption 323 KWh/year

Energy efficiency class F

Airborne acoustical noise emission class C

Total volume 320 l

Sum of the volumes of the chill compartment(s) and the unfrozen compartment(s) 320 l

Noise level 41 dB(A) re 1 pW

Thaw time 10 h

Climatic class SN, N, ST, T

Sum of the volumes of the frozen compartment(s) 105 l

EEl







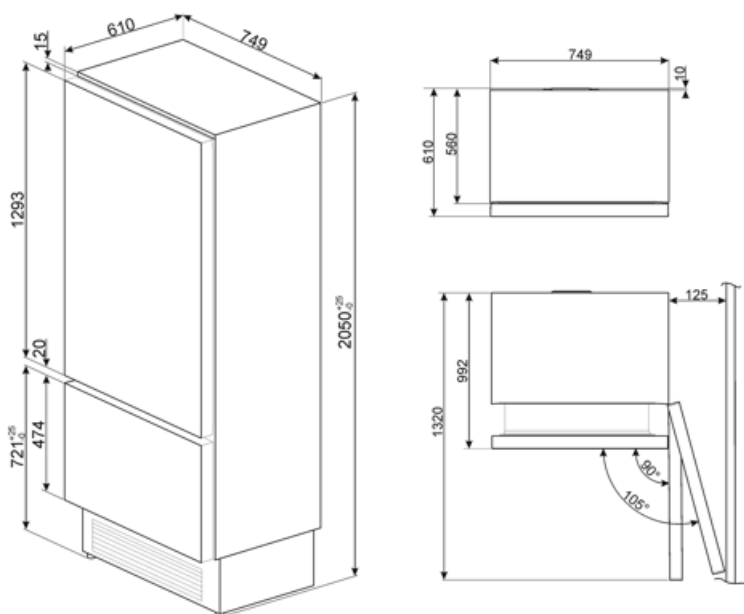







122 %

## Electrical Connection

Plug	(F;E) Schuko	Voltage (V)	220-240 V
Nominal power	240 W	Frequency (Hz)	50 Hz
Current	1,4 A	Power supply cable length	200 cm



## Symbols glossary

- |   |  |
|---|--|
|  <p>4 stars freezing compartment for better food preservation.</p>  |  <p>A+: Energy efficiency class A+ helps to save up to 10% energy compared to class A. Maximum performance with minimum consumption is guaranteed.</p>  |
|  <p>The automatic defrost system works by automatically defrosting at regular intervals eliminating the need to defrost altogether.</p> |  <p>Child lock: some models are fitted with a device to lock the programme/cycle so it cannot be accidentally changed.</p>  |
|  <p>LCD display: to optimize performance and simplify the use of the appliance.</p>   |  <p>Fast freezing: The fast freezing function brings the temperature of the compartment down when activated a few hours prior to usage.</p>   |
|  <p>Power saving mode: The power saving mode allows you to disable the refrigerator and keep the freezer working.</p>                   |  <p>LED interior lighting: is a more energy efficient and long lasting way of illuminating the interior of the appliance.</p>   |
|  <p>Life Plus 0°C: The temperature in the Lifeplus compartments is kept at 0°C, which preserves fresh meat and fish longer.</p>         |  <p>Inverter technology: The evolution of Smeg's driers towards more intelligent and environmentally sustainable models has led to the choice of using Inverter technology with heat pumps, which reduces significantly energy consumption.</p> |
|  <p>Air plus: keeps food fresher for longer.</p>  |  <p>Multizone: Multizone compartment can be used as a refrigerator or a freezer compartment. Depending on your needs and eating habits, you can select settings, program the temperature using.</p>   |
|  <p>No Frost: The No Frost and Frost free systems prevent ice from forming so that no defrosting is required.</p>                     |  <p>Sabbath: This function allows you to cook food whilst respecting the provisions of the Jewish day of rest.</p>  |
|  <p>Energy efficiency class F</p>   |  |

---

## Benefit

---

### **Plastic multiflow system**

The Multiflow system ensures even distribution of cold air inside the refrigerator

### **Multizone (variable temperature compartment)**

The Multizone system isolates a freezer compartment with adjustable temperature independent of the main compartment, to give maximum storage flexibility

The Multizone compartment can be used both as a freezer and as a refrigerator. Depending on one's needs and eating habits, each user can choose how to set it, programming the temperature via the external display.

### **Refrigerant gas R600a**

Environmentally friendly R600a refrigerant gas contributes to rapid cooling with lower energy consumption

### **Climate class**

Climatic class SN-T makes the appliance suitable for working at room temperature between 10 °C and 43 °C (50 °F ~ 109 °F)

### **Self-supporting hinges**

Self-supporting hinges ensure a perfect fit between the equipment door and the cabinet door, giving the product a minimalist and elegant appearance

### **Life Plus 0°**

Temperature-controlled Life Plus compartment for optimal storage of specific food categories

### **Refrigerator Internal lighting**

Interior lighting for perfect visibility of shelves in the refrigerator compartment

### **Freezer internal lighting**

Interior lighting for perfect visibility of the drawers in the freezer compartment

### **Fruit and vegetable drawer**

The fruit and vegetable drawer ensures the best storage conditions for fresh food, avoiding any contamination

### **Inverter compressor**

Inverter compressor reduces noise and vibration levels for a quiet and comfortable kitchen environment

Inverter compressor technology offers significant advantages for refrigeration systems, improving both performance and efficiency. Better temperature control ensures a more stable and constant indoor environment, preserving the freshness of food. This technology also results in reduced energy consumption, as the compressor adjusts its speed according to cooling needs.

## Automatic Ice Maker

Automatic ice maker for ice always available when needed

The automatic ice maker is connected directly to the kitchen water supply, so there is no need to manually fill any tanks. This saves considerable time and ensures hygiene and convenience.