

RI96RSI



| | |
|-------------------------|---|
| Product Family | Refrigerator |
| Installation | Built-in |
| Category | Bottom Mount |
| Built-in niche | >200 |
| Reference width | Higher than 80 |
| Reference height | Higher than 200 |
| No-Frost system | Total |
| Cooling type | Fan assisted refrigerator, no-frost freezer |
| Defrost | Automatic |
| Hinge type | Door on door |
| Hinge position | Right |
| EAN code | 8017709205089 |



Aesthetics



| | | | |
|----------------------|--------------|---------------------|-------------|
| Aesthetics | Universal | Side colour | Silver |
| Material | Metal sheet | Logo | Silk screen |
| Handle | Not included | Display | LCD Touch |
| Side material | Steel | Water Filter | Internal |

Refrigerator compartment features

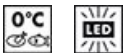

| | | | |
|--|------------------|--|-------|
| No. of adjustable shelves | 3 | Type of crisper/vegetable drawers cover | Glass |
| Number of fruit and vegetables drawers | 1 | Life Plus zone-0°C | Yes |
| Type of adjustable shelves | Glass | Internal light in fridge | Yes |
| Type of crisper/vegetable drawers cover | On sliding rails | Type of internal light (fridge) | LED |
| Crisper Cover | Yes | | |

Refrigerator Inner Door

| | | | |
|--|-----|---|-----|
| Number of adjustable door shelves | 2 | No. of bottle shelves | 1 |
| Adjustable door shelves with wire support | Yes | Bottle shelves with wire support | Yes |

Other Refrigerator features



MultiFlow Yes

Freezer compartment features

Number of drawers 2
 Internal light in freezer Yes
 Type of internal light (freezer) LED

Other Freezer features

Ice maker Automatic
 Ice tray shelf Yes

Other technical features



Functions display

Holiday, Fast freezing, Fast cooling, MultiZone, Control lock, Temperature alarm, Cooling timer, Demo Mode, Sabbath

MultiZone

Yes

Water network connection

Yes

Temperature alarm lamp

Yes

Door open alarm

Yes

Temperature Alarm

Acoustic and visual

Type of temperature control

Electronic

No. of compressors

2

Refrigerant gas type

R600a

Type of compressor

Variable Speed Compressor

Refrigerant Quantity (gr)

48 g

Foam agent

Cyclopentane

Performance / Energy Label



Annual energy consumption 342 kWh/year

Energy efficiency class F

Airborne acoustical noise emission class C

Total volume 131 l

Sum of the volumes of the frozen compartment(s) 131 l

Sum of the volumes of the chill compartment(s) and the unfrozen compartment(s) 425 l

Noise level 41 dB(A) re 1 pW

Thaw time 10 h







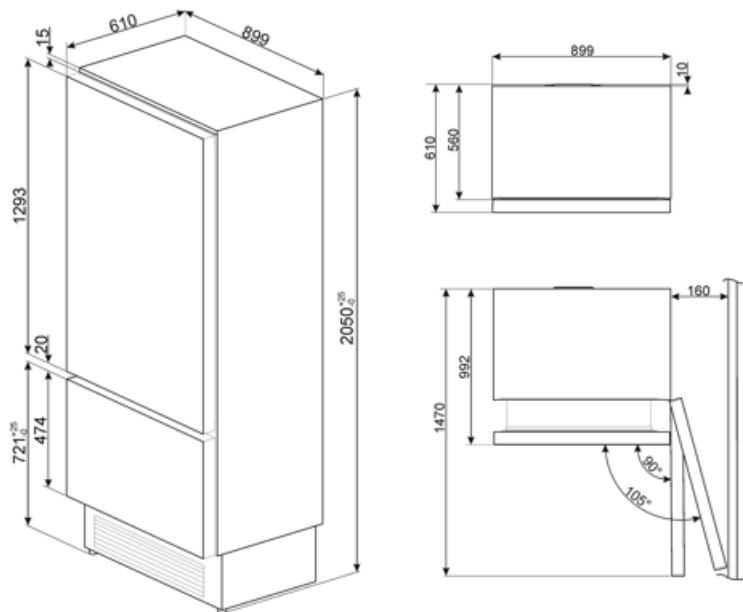







Climatic class SN, N, ST, T
 EEI 116 %

Electrical Connection

| | | | |
|---------------|--------------|---------------------------|-----------|
| Plug | (F;E) Schuko | Voltage (V) | 220-240 V |
| Nominal power | 240 W | Frequency (Hz) | 50 Hz |
| Current | 1,5 A | Power supply cable length | 250 cm |



Symbols glossary

- | | |
|---|--|
|  <p>4 stars freezing compartment for better food preservation.</p> |  <p>A+: Energy efficiency class A+ helps to save up to 10% energy compared to class A. Maximum performance with minimum consumption is guaranteed.</p> |
|  <p>The automatic defrost system works by automatically defrosting at regular intervals eliminating the need to defrost altogether.</p> |  <p>Child lock: some models are fitted with a device to lock the programme/cycle so it cannot be accidentally changed.</p> |
|  <p>LCD display: to optimize performance and simplify the use of the appliance.</p> |  <p>Fast freezing: The fast freezing function brings the temperature of the compartment down when activated a few hours prior to usage.</p> |
|  <p>Power saving mode: The power saving mode allows you to disable the refrigerator and keep the freezer working.</p> |  <p>LED interior lighting: is a more energy efficient and long lasting way of illuminating the interior of the appliance.</p> |
|  <p>Life Plus 0°C: The temperature in the Lifeplus compartments is kept at 0°C, which preserves fresh meat and fish longer.</p> |  <p>Inverter technology: The evolution of Smeg's driers towards more intelligent and environmentally sustainable models has led to the choice of using Inverter technology with heat pumps, which reduces significantly energy consumption.</p> |
|  <p>Air plus: keeps food fresher for longer.</p> |  <p>Multizone: Multizone compartment can be used as a refrigerator or a freezer compartment. Depending on your needs and eating habits, you can select settings, program the temperature using.</p> |
|  <p>No Frost: The No Frost and Frost free systems prevent ice from forming so that no defrosting is required.</p> |  <p>Sabbath: This function allows you to cook food whilst respecting the provisions of the Jewish day of rest.</p> |
|  <p>Energy efficiency class F</p> | |