

# S4F094E



Product Family	Freezers
Installation	Built-in
Built-In Niche	88 cm
Category	Single door
Cooling type	Static
Hinge type	Sliding
Hinge position	Right
Reversible door	Yes



## Aesthetics

Aesthetic	Universale	Side material	Metal
Colour	White	Side colour	White
Design	Flat	Logo	Silk screen
Material	Steel	Drawers profile color	Bianco

## Freezer compartment features

Number of drawers	4
-------------------	---

## Other technical features

Freezer compartment accessories	Ice cube tray	No. of compressors	1
Fast freezing button	Yes	Refrigerant gas type	R600a
Power on lamp	Yes	Type of compressor	Standard
Temperature alarm lamp	Yes	Refrigerant Quantity (g)	60 g
Temperature alarm	Yes	Foam agent	Cyclopentane
Type of temperature control	Electro-mechanical		

## Performance / Energy Label - Reg. 2019



Annual energy consumption	177 kWh/a	Temperature Rise Time	12,70 h
---------------------------	-----------	-----------------------	---------

Total net volume	98 l	4 star - Freezing capacity	4,5 kg/24h
Energy efficiency class	E	Climate class	SN, N, ST, T
Airborne acoustical noise emission class	B	EEl	100 %
Sum of the volumes of the frozen compartment(s)	98 l		

## Electrical Connection



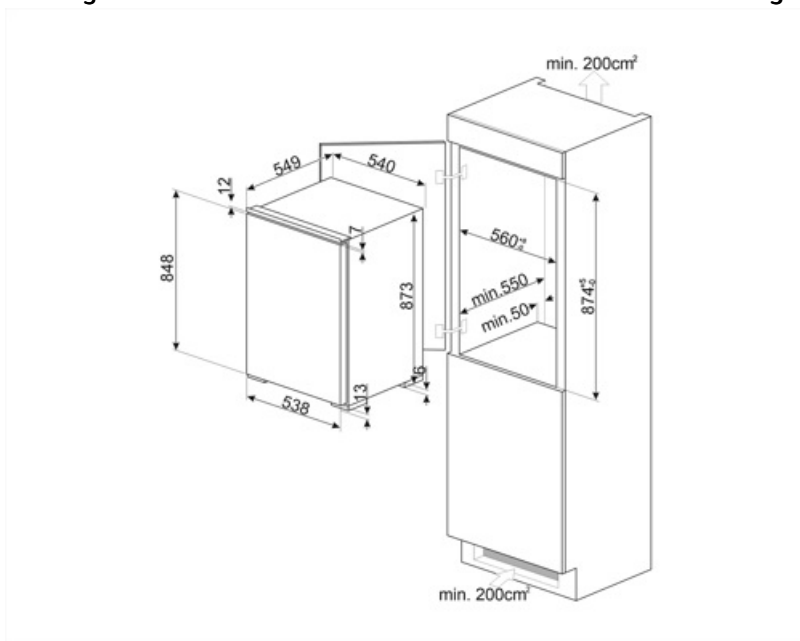

Electrical connection rating	120 W	Frequency (Hz)	50 Hz
Current	0,8 A	Power supply cable length	240 cm
Voltage	230-240 V	Plug	(F;E) Schuko



---

## Symbols glossary

---

	4 stars freezing compartment for better food preservation.		A++: Energy efficiency class A++ helps to save up to 20% energy compared to class A. Maximum performance with minimum consumption is guaranteed.
	Built-in niche		Energy efficiency class E