

# S8F174NE



Product Family	Freezers
Installation	Built-in
Built-In Niche	178
Category	Single door
Cooling type	No Frost
Hinge type	Sliding
Hinge position	Right
Reversible door	Yes



## Aesthetics



Aesthetic	Universale	Side colour	White
Colour	White	Logo	Silk screen
Material	Steel	Drawers profile color	Silver
Side material	Metal	Display	LCD Touch

## Freezer compartment features

Number of drawers	5
No. of compartments with flap	2

## Other technical features



Freezer compartment accessories	Accumulator, Ice cube tray	No. of compressors	1
Functions display	Fast Freezing, Temperature Alarm, Cooling timer	Refrigerant gas type	R600a
Fast freezing button	Yes	Type of compressor	Standard
Temperature alarm lamp	Yes	Refrigerant Quantity (gr)	48 g
Type of temperature control	Electronic	Foam agent	Cyclopentane

## Performance / Energy Label - Reg. 2019







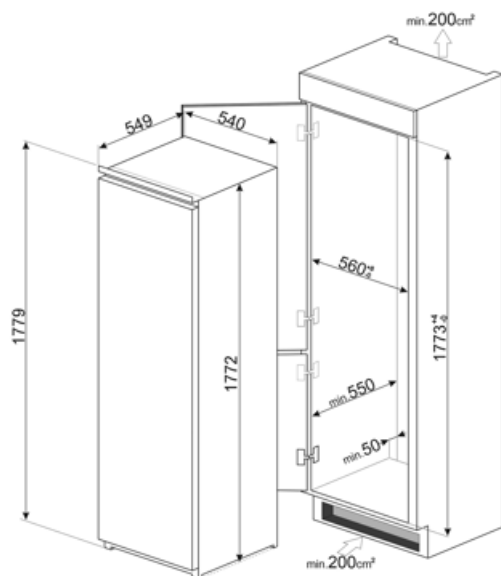

<b>Annual energy consumption</b>	233 kWh/a	<b>Temperature Rise Time</b>	9.00 h
<b>Total net volume</b>	204 l	<b>4 star - Freezing capacity</b>	15.7 Kg/24h
<b>Energy efficiency class</b>	E	<b>Climate class</b>	SN, N, ST, T
<b>Airborne acoustical noise emission class</b>	C	<b>EEl</b>	100 %
<b>Sum of the volumes of the frozen compartment(s)</b>	204 l		

## Electrical Connection

<b>Plug</b>	(F;E) Schuko	<b>Voltage</b>	230-240 V
<b>Electrical connection rating</b>	140 W	<b>Frequency (Hz)</b>	50 Hz
<b>Current</b>	1 A	<b>Power supply cable length</b>	240 cm



## Symbols glossary

- |  |   |   |  |
|--|---|---|--|
|  | 4 stars freezing compartment for better food preservation.                  |  | A+: Energy efficiency class A+ helps to save up to 10% energy compared to class A. Maximum performance with minimum consumption is guaranteed. |
|  | LCD display: to optimize performance and simplify the use of the appliance. |  | Fast freezing: The fast freezing function brings the temperature of the compartment down when activated a few hours prior to usage.            |
|  | Built-in niche  |  | No Frost: The No Frost and Frost free systems prevent ice from forming so that no defrosting is required.                                      |
|  | Energy efficiency class E   |   |  |