

## S9C1741E



Product Family	Refrigerator
Installation	Built-in
Category	One Door
Built-in niche	178
Reference width	Until 60
Reference height	160 - 200
Cooling type	Fan assisted refrigerator, static freezer
Defrost	Automatic for refrigerator, manual for freezer
Hinge type	Sliding
Hinge position	Right
Reversible door	Yes
EAN code	8017709348014



## Aesthetics



Aesthetic	Universal	Cor do perfil da prateleira de vidro	Chrome
Colour	White	Display	LED
Material	Metal sheet	Mostrar porções	Interno (no Topo)
Side material	Steel	Dispenser	No
Side colour	White	Water Filter	No
Cor do perfil das prateleiras da porta	Silver	HomeBar	No
Cor do perfil das gavetas	Silver		

## Refrigerator compartment features



No. of adjustable shelves	4	Type of crisper/vegetable drawers cover	Glass
Number of fruit and vegetables drawers	1	Nº de lâmpadas	2
Type of adjustable shelves	Glass	Life Plus zone-0°C	No
Type of crisper/vegetable drawers cover	On sliding rails	Compartimento baixa temperatura	No
Crisper Cover	Yes	Internal light in fridge	Yes
Bottle shelf	No	Type of internal light (fridge)	LED

## Refrigerator Inner Door

No. of door shelves with transparent cover	1	No. of bottle shelves	1
Number of adjustable door shelves	3	Bottle shelves with wire support	No
Adjustable door shelves with wire support	No		

## Other Refrigerator features



Accessories	Egg tray	Fan	Yes
Natural Plus Blu Light	No	Ionizer	No
MultiFlow	No		

## Freezer compartment features

Internal freezer compartment	Yes	Type of internal light (freezer)	No
Internal light in freezer	No		

## Other technical features



Functions display	Fast cooling
Door open alarm	Yes
Temperature Alarm	No
Type of temperature control	Electronic
No. of compressors	1
Refrigerant gas type	R600a
Type of compressor	Inverter
Refrigerant Quantity (gr)	48 g

## Etiqueta de Desempenho / Energia - Reg. 2019



Consumo de energia anual	166 kWh/a	Airborne acoustical noise emissions	31 dB(A) re 1 pW
Classe de eficiência energética	E	Autonomia de conservação sem energia elétrica	14 h
Classe de emissão de ruído acústico aerotransportado	B	4 estrelas - Capacidade de congelamento	5.5 Kg/24h
Volume líquido total	286 l	Classe climática	SN, N, ST
Soma dos volumes do(s) compartimento(s) congelado(s)	22 l	EEl	100 %





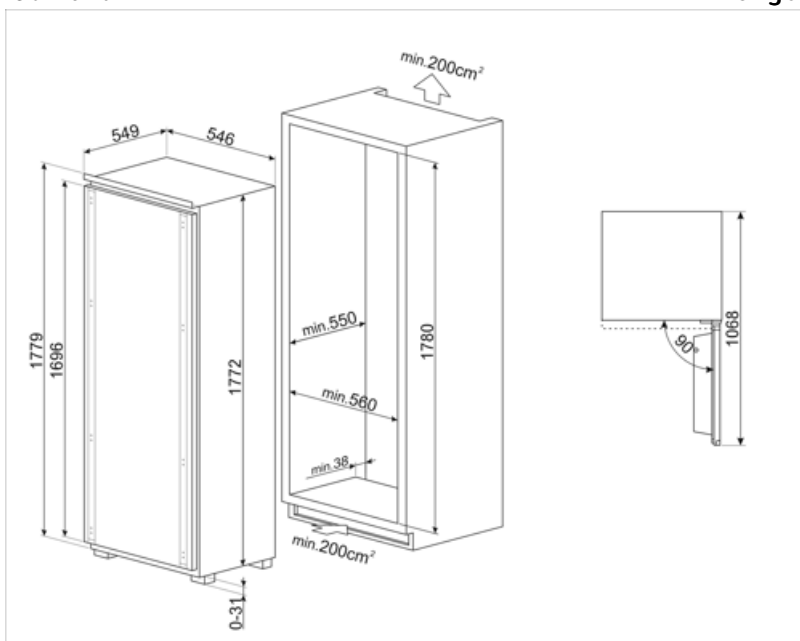

Soma dos volumes do(s) 264 l  
 compartimento(s)  
 refrigerado(s) e do(s)  
 compartimento(s) não  
 congelado(s)

## Electrical Connection

Plug	(F;E) Schuko	Voltage (V)	230-240 V
Electrical connection rating	130 W	Frequency (Hz)	50 Hz
Current	1 A	Power supply cable length	240 cm



## Symbols glossary

- |   |  |
|---|--|
|  <p>O sistema de descongelamento automático funciona descongelando automaticamente em intervalos regulares, eliminando a necessidade de descongelar completamente.</p>  |  <p>Display LED: para mostrar os programas, funções e opções selecionadas e o tempo até ao final do ciclo.</p>                    |
|  <p>Ventilado: Distribuição forçada de ar frio no compartimento da geladeira, o que permite uma distribuição uniforme da temperatura dentro da geladeira.</p>   |  <p>Iluminação interior LED: é uma forma mais eficiente em termos energéticos e duradoura de iluminar o interior do aparelho.</p> |
|  <p>Tecnologia do inversor: A evolução dos secadores Smeg para modelos mais inteligentes e ambientalmente sustentáveis levou à escolha do uso da tecnologia do inversor com bombas de calor, o que reduz significativamente o consumo de energia.</p> |  <p>Nicho incorporado</p>   |
|  <p>Classe de eficiência energética E.</p>  |  |

## Benefit (TT)

---

### **Fan**

The fan contributes to an even distribution of air inside the refrigerator

### **Refrigerant gas R600a**

Environmentally friendly R600a refrigerant gas contributes to rapid cooling with lower energy consumption

### **Refrigerator Internal lighting**

Interior lighting for perfect visibility of shelves in the refrigerator compartment

### **Fruit and vegetable drawer**

The fruit and vegetable drawer ensures the best storage conditions for fresh food, avoiding any contamination

### **Inverter compressor**

Inverter compressor reduces noise and vibration levels for a quiet and comfortable kitchen environment

Inverter compressor technology offers significant advantages for refrigeration systems, improving both performance and efficiency. Better temperature control ensures a more stable and constant indoor environment, preserving the freshness of food. This technology also results in reduced energy consumption, as the compressor adjusts its speed according to cooling needs.

### **Internal display**

Internal display for targeted temperature control and a clean, minimalist design